

TWIN-GUIDE CYLINDER

Handling

⚠ Caution

① Please control the cylinder within the allowable speed range:

If the cylinder is not using the speed control valve, it may occur beyond the speed range of the piston. If it is used outside the allowable speed range, it will cause cylinder damage or reduce product life. Therefore, please install the speed control valve and adjust the speed within the allowable range. The product allowable speed is shown in Table 1.

② Please note the speed control during vertical installation:

When the cylinder is used vertically, if the load rate is large, it will cause the speed control valve to exceed the upper limit and could cause sudden unintended acceleration which will affect the product life. Therefore, it is recommended to use a dual speed controller.

③ The lateral load of the cylinder during the operation must be within the allowable range:

Exceeding the allowable value will prevent the cylinder from operating properly and affect the life of the product.

④ Do not scratch the mounting surface of the cylinder body and end plate to avoid affecting the flatness:

If the flatness of the mounting surface is poor, the cylinder will malfunction. The mounting surface of the cylinder body and the end plate should have a flatness of less than 0.05 mm.

⑤ Do not cause surface damage or impact marks on the operating parts of the piston rod and the guide rod:

Damage to the appearance will result in damage to the seal ring which could cause leakage or malfunction of the cylinder.

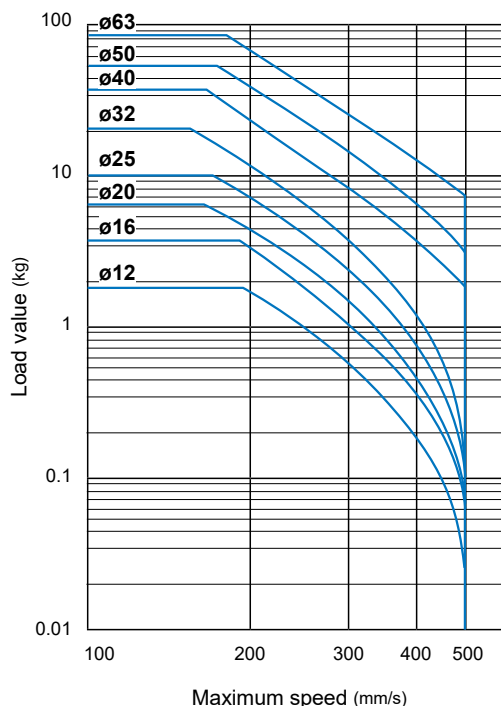

Table 1



$\phi 12 \sim \phi 63$



Applications



Technical data



Caution for safety
(Read before installing)



Features

- Multi-ports as standard enabling both direction mounting.
- Embedding type sensors.
- The sensor cable will be in the same direction as the piping tube if vertical type sensor switch (Angle cable) is used.
- Magnetic as standard.

Specification

Model	MCGS	
Acting type	Double acting	
Tube I.D. (mm)	6	10
Stroke (mm)	5, 10, 15	5, 10, 15, 20
Port size	M3×0.5	
Medium	Air	
Max. operating pressure	0.7 MPa	
Min. operating pressure	0.15 MPa	
Proof pressure	1 MPa	
Lubrication	Not required	
Ambient temperature	-5~+60°C (No freezing)	
Available speed range	50~400 mm/sec	
Sensor switch	RDCV, RQCV , RDGV	

* This product is not applicable for stopper purpose.

Order example

MCGS - 6 - 10

MODEL

TUBE I.D.

STROKE

Cylinder weight

Unit: g

Tube I.D.	Stroke (mm)			
	5	10	15	20
$\phi 6$	29	34	39	—
$\phi 10$	41	49	57	65

Installation of sensor switch

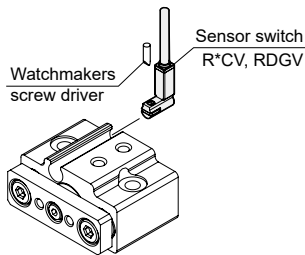

Allowable rotational torque & Non-rotating accuracy

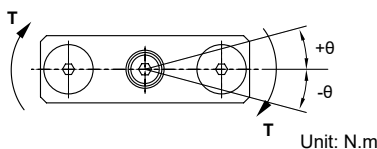

Tube I.D.	Stroke (mm)				Non-rotating accuracy θ
	5	10	15	20	
$\phi 6$	0.9	0.7	0.6	—	$\pm 0.15^\circ$
$\phi 10$	4.7	3.9	3.3	2.8	

Allowable lateral load

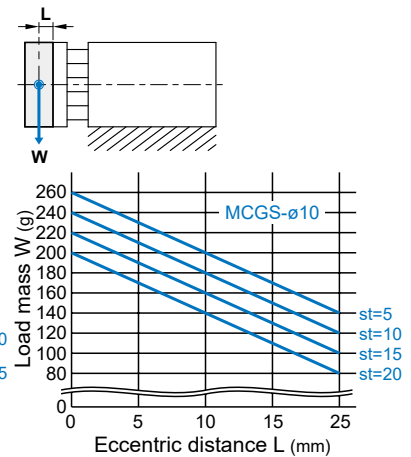
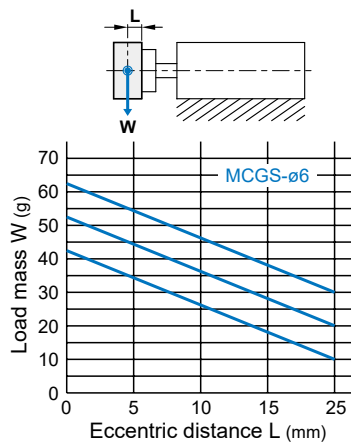

Allowable eccentric load

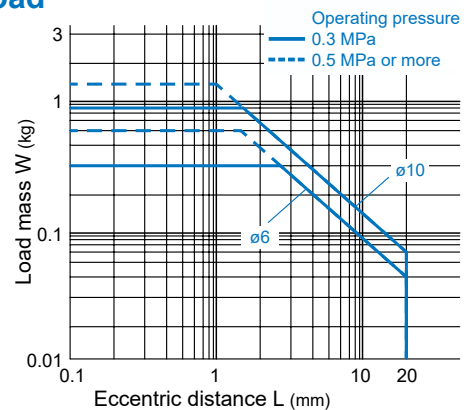
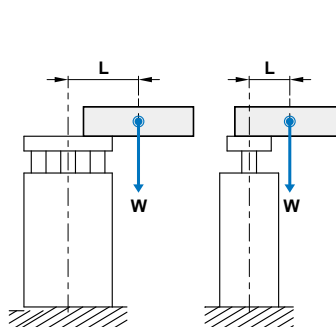

TWIN-GUIDE CYLINDER

Inside structure & Parts list

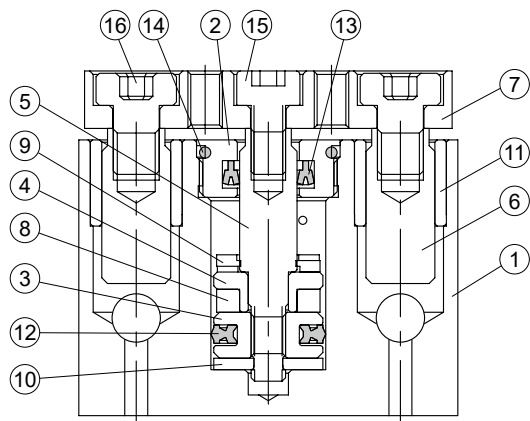

Material

No.	Part name	Material	Q'y	Repair kits (inclusion)
1	Body	Aluminum alloy	1	
2	Rod cover	Aluminum alloy	1	
3	Piston-H	Aluminum alloy	1	
4	Piston-R	Aluminum alloy	1	
5	Piston rod	Stainless steel	1	
6	Guide rod	Carbon steel	2	
7	Plate	Aluminum alloy	1	
8	Magnet ring	Magnet material	1	
9	Cushion	NBR	1	●
10	Cushion	NBR	1	●
11	Bush	Copper	2	
12	Piston seal	NBR	1	●
13	Rod seal	NBR	1	●
14	O-ring	NBR	1	●
15	Screw	Carbon steel	1	
16	Screw	Carbon steel	2	

Order example of repair kits

Tube I.D.	Repair kits
$\varnothing 6$	PS-MCGS-6
$\varnothing 10$	PS-MCGS-10

Dimensions

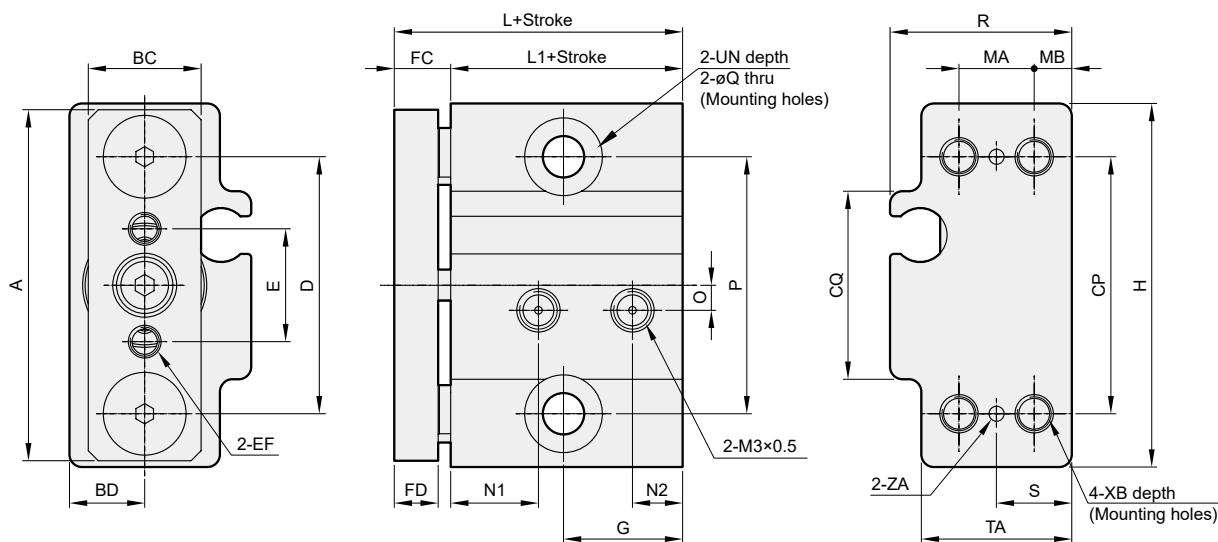

Code Tube I.D.	A	BC	BD	CP	CQ	D	E	EF	FC	FD	G	H	L	L1	MA	MB	N1	N2
6	28	9	6	20.5	15	20.5	9	M2.5×0.45 thru	4.5	3.5	9.5	29	23	18.5	6	3	7	4
10	32	10	7.5	23	17.5	23	11	M3×0.5 thru	6	5	8.5	33	25	19	8	3.5	7	4.5

Code Tube I.D.	O	P	Q	R	S	TA	UN	XB	ZA
6	2	20.5	3.3	14.5	6	12	$\varnothing 6.2 \times 0.5$	M3×0.5×5	$\varnothing 1.2$
10	3	23	4.3	17	7.5	15	$\varnothing 8 \times 0.5$	M4×0.7×5	$\varnothing 2$

TWIN-GUIDE CYLINDER

Handling

⚠ Caution

1 Please control the cylinder within the allowable speed range:

If the cylinder is not using the speed control valve, it may occur beyond the speed range of the piston. If it is used outside the allowable speed range, it will cause cylinder damage or reduce product life. Therefore, please install the speed control valve and adjust the speed within the allowable range. The product allowable speed is shown in Table 1.

2 Please note the speed control during vertical installation:

When the cylinder is used vertically, if the load rate is large, it will cause the speed control valve to exceed the upper limit and could cause sudden unintended acceleration which will affect the product life. Therefore, it is recommended to use a dual speed controller.

3 The lateral load of the cylinder during the operation must be within the allowable range:

Exceeding the allowable value will prevent the cylinder from operating properly and affect the life of the product.

4 Do not scratch the mounting surface of the cylinder body and end plate to avoid affecting the flatness:

If the flatness of the mounting surface is poor, the cylinder will malfunction. The mounting surface of the cylinder body and the end plate should have a flatness of less than 0.05 mm.

5 Do not cause surface damage or impact marks on the operating parts of the piston rod and the guide rod:

Damage to the appearance will result in damage to the seal ring which could cause leakage or malfunction of the cylinder.

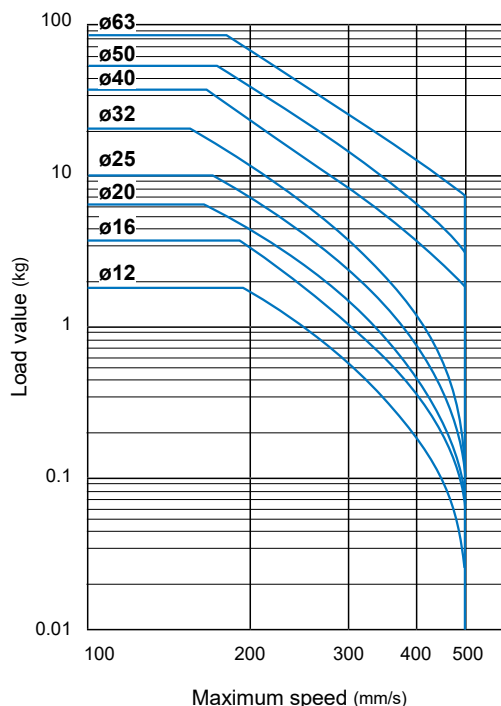

Table 1



ø6, ø10



Applications



Technical data







Caution for safety
(Read before installing)

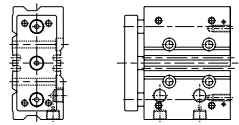

Features

- Proven track record in manufacturing precision guided cylinders.
- Multi-Ports as standard enabling two direction mounting option.
- Flush fitting sensors.
- Magnetic as standard

Specification

Model	MCGS		
Model			
Acting type	Double acting		
Tube I.D. (mm)	12,16	20,25,32,40	50,63
Port size	M5×0.8	Rc1/8	Rc1/4
Medium	Air		
Operating pressure range	0.1~1 MPa		
Proof pressure	1.5 MPa		
Ambient temperature	-5~+60°C (No freezing)		
Cushion	With rubber cushion pad		
Available speed range	50~500 mm/sec		
Lubrication	Not required		
Sensor switch (*)	RCE  , RCE1  , RDEP 		

Order example

MCGS – 03 – 12 – 50 – 20 – G

MODEL

TUBE I.D.

STROKE

ADJUST STROKE
(for 07, 27 type)

PORT THREAD
Blank: M5×0.8
(for ø12, ø16)
Blank: Rc thread
G: G thread
NPT: NPT thread
(for ø20~ø63)

PURPOSE / TYPE OF BEARING

Code	Purpose / Type of bearing
03	Stop / Slide bush
07	Stop / Slide bush / Stroke adjustable
23	Push / Linear bearing (Could attach a table for the use as a lifter)
27	Push / Linear bearing / Stroke adjustable (Could attach a table for the use as a lifter)

* For precautions .

Table for standard stroke

Series variety (Bearing type)	Tube I.D.	Stroke (mm)															
		10	20	25	30	40	50	75	100	125	150	175	200	250	300	350	400
MCGS-03 MCGS-07 (Slide bush)	ø12																
	ø16																
	ø20																
	ø25																
	ø32*																
	ø40																
	ø50																
MCGS-23 MCGS-27 (Linear bearing)	ø63																
	ø12																
	ø16																
	ø20																
	ø25																
	ø32*																
	ø40																
ø50																	
ø63																	

* Tube I.D. ø32: 25mm for the shortest standard stroke.

* Adjustable air cushion type, please contact us.

Installation of sensor switch

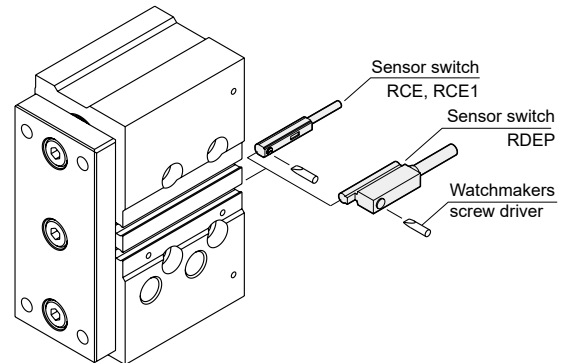

Capacity graph

Capacity for the use as a stopper

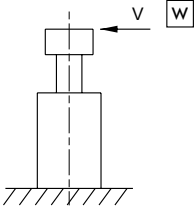

Linear bearing type is not available as a stopper.

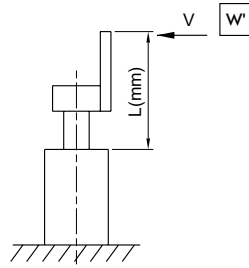

$$W = W' \times \frac{L}{\ell}$$

For the use of attaching a plate to the link bar, choose a bore size referring to the formula below.

W: The maximum weight of the work carrier in the above graph for the stopper's capacity.

Stop capacity

MCGS-03/07...30st $\phi 12 \sim \phi 32$

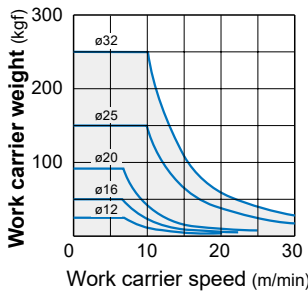

MCGS-03/07...25st $\phi 40 \sim \phi 63$

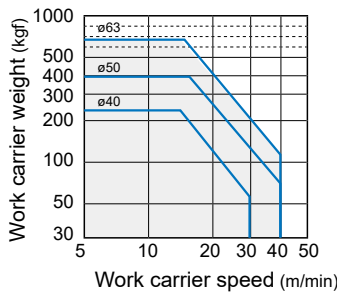

Normal lateral load

MCGS-03/07...30st

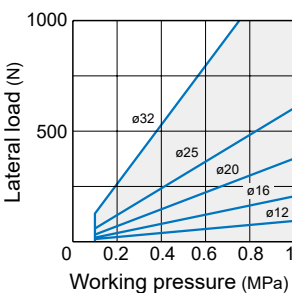

Coefficients for conversion

Tube I.D.	ℓ
$\phi 12$	40
$\phi 16$	42
$\phi 20$	42
$\phi 25$	42
$\phi 32$	44
$\phi 40$	72
$\phi 50$	78
$\phi 63$	78

Capacity for the use as a lifter

Allowable eccentricity load for the use as a lifter (at supply pressure 0.5 MPa)

Show the dynamic allowable value at L(mm) eccentricity from the center of the guide rod.

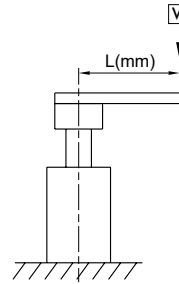

Slide bush MCGS-03/07

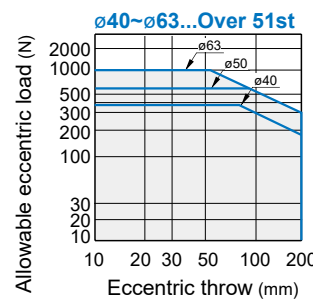
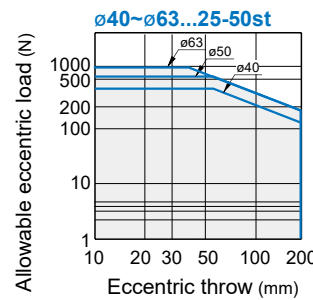
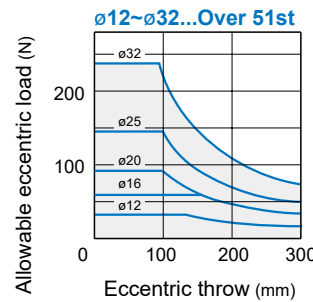
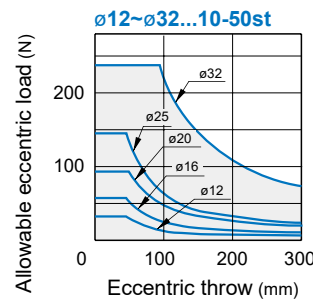

Linear bearing MCGS-23/27

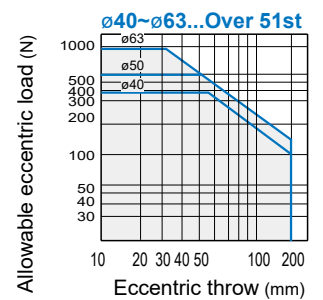
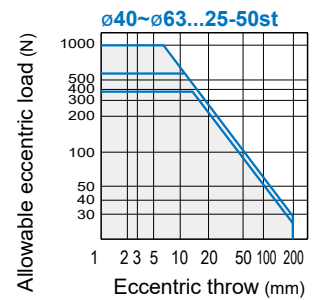
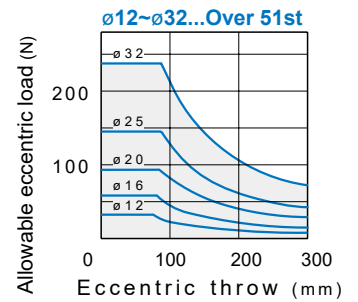
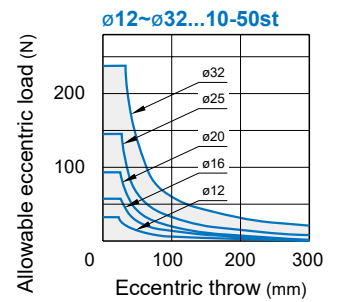

Unit: N

Capacity table

Allowable lateral load

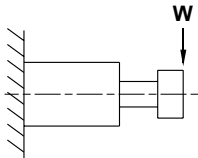

Shows the dynamic allowable value, when actuating the cylinder with lateral load W at the guide rods' top (vertical load against the guide rods).

Tube I.D.	Bearing type	Stroke (mm)															
		10	20	25	30	40	50	75	100	125	150	175	200	250	300	350	400
$\phi 12$	Slide bush	31	24	—	19	16	13	37	31	15	13	12	10	9	—	—	—
	Linear bearing	23	17	—	14	34	30	23	19	12	11	9	8	6	—	—	—
$\phi 16$	Slide bush	50	39	—	32	27	24	54	45	27	24	21	19	16	—	—	—
	Linear bearing	36	29	—	24	59	52	40	33	20	17	15	13	10	—	—	—
$\phi 20$	Slide bush	—	51	—	44	39	35	54	46	74	66	59	54	28	24	21	19
	Linear bearing	—	43	—	36	98	87	69	57	46	40	36	32	32	27	23	20
$\phi 25$	Slide bush	—	68	—	59	52	46	72	61	98	88	79	72	53	46	41	37
	Linear bearing	—	67	—	56	148	132	105	87	70	62	55	50	42	36	30	27
$\phi 32$	Slide bush	—	—	165	—	—	129	106	90	138	123	111	101	88	77	68	61
	Linear bearing	—	—	104	—	—	74	165	138	114	100	90	81	66	56	48	42
$\phi 40$	Slide bush	—	—	203	—	—	164	182	159	142	127	190	174	150	132	118	106
	Linear bearing	—	—	113	—	—	78	129	106	130	114	106	95	78	67	58	50
$\phi 50$	Slide bush	—	—	296	—	—	245	273	241	216	195	190	174	150	132	118	106
	Linear bearing	—	—	120	—	—	83	178	148	148	129	106	95	78	67	58	50
$\phi 63$	Slide bush	—	—	296	—	—	245	273	241	216	195	—	—	—	—	—	—
	Linear bearing	—	—	117	—	—	81	176	145	145	126	—	—	—	—	—	—

Allowable rotating torque

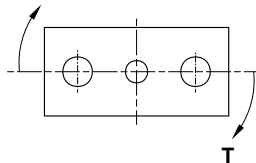

Shows the dynamic allowable value, when actuating the cylinder with a rotating torque T at the guide rods' top.

Unit: N.m

Tube I.D.	Bearing type	Stroke (mm)															
		10	20	25	30	40	50	75	100	125	150	175	200	250	300	350	400
$\phi 12$	Slide bush	0.64	0.48	—	0.39	0.32	0.28	0.75	0.63	0.15	0.13	0.12	0.11	0.09	—	—	—
	Linear bearing	0.47	0.35	—	0.29	0.71	0.62	0.40	0.38	0.13	0.11	0.09	0.08	0.07	—	—	—
$\phi 16$	Slide bush	1.14	0.90	—	0.74	0.63	0.55	1.23	1.04	0.31	0.27	0.24	0.22	0.18	—	—	—
	Linear bearing	0.84	0.66	—	0.54	1.35	1.19	0.93	1.76	0.23	0.19	0.17	0.15	0.12	—	—	—
$\phi 20$	Slide bush	—	1.14	—	1.21	1.07	0.95	1.49	1.25	2.03	1.81	1.63	1.48	0.37	0.32	0.29	0.26
	Linear bearing	—	1.19	—	0.99	2.69	2.40	1.89	1.56	1.26	1.10	0.98	0.88	0.43	0.36	0.31	0.27
$\phi 25$	Slide bush	—	2.19	—	1.88	1.65	1.47	2.31	1.94	3.15	2.80	2.52	2.30	0.85	0.74	0.66	0.59
	Linear bearing	—	2.14	—	1.79	4.74	4.22	3.36	2.78	2.25	1.98	1.76	1.59	0.68	0.57	0.49	0.42
$\phi 32$	Slide bush	—	—	6.61	—	—	5.16	4.23	3.59	5.52	4.93	4.45	4.06	1.72	1.50	1.33	1.20
	Linear bearing	—	—	4.17	—	—	2.95	6.60	5.52	4.56	4.02	3.59	3.24	1.29	1.09	0.94	0.82
$\phi 40$	Slide bush	—	—	7.00	—	—	5.66	6.27	5.48	4.87	4.38	5.21	4.79	4.13	3.63	3.23	2.92
	Linear bearing	—	—	5.24	—	—	4.25	7.19	6.33	7.81	7.11	2.93	2.61	2.16	1.83	1.58	1.39
$\phi 50$	Slide bush	—	—	13.0	—	—	10.8	12.0	10.6	9.50	8.60	5.88	5.41	4.66	4.09	3.65	3.29
	Linear bearing	—	—	7.02	—	—	5.76	12.3	10.9	11.2	10.2	3.30	2.94	2.43	2.06	1.78	1.57
$\phi 63$	Slide bush	—	—	14.7	—	—	12.1	13.5	12.0	10.7	9.69	—	—	—	—	—	—
	Linear bearing	—	—	7.77	—	—	3.35	13.7	12.2	12.5	11.4	—	—	—	—	—	—

Anti-roll accuracy

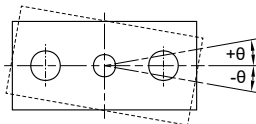

- The values are the deflection angle against the piston rod.
- Exclusive factor of the guide rods' deflection.

Tube I.D.	Bearing type	Anti-roll accuracy
		θ
$\phi 12$	Slide bush	$\pm 0.09^\circ$
	Linear bearing	$\pm 0.06^\circ$
$\phi 16$	Slide bush	$\pm 0.08^\circ$
	Linear bearing	$\pm 0.06^\circ$
$\phi 20$	Slide bush	$\pm 0.08^\circ$
	Linear bearing	$\pm 0.03^\circ$
$\phi 25$	Slide bush	$\pm 0.07^\circ$
	Linear bearing	$\pm 0.05^\circ$
$\phi 32$	Slide bush	$\pm 0.07^\circ$
	Linear bearing	$\pm 0.03^\circ$
$\phi 40$	Slide bush	$\pm 0.06^\circ$
	Linear bearing	$\pm 0.08^\circ$
$\phi 50$	Slide bush	$\pm 0.05^\circ$
	Linear bearing	$\pm 0.06^\circ$
$\phi 63$	Slide bush	$\pm 0.05^\circ$
	Linear bearing	$\pm 0.06^\circ$

MCGS-03 Inside structure & Parts list

TWIN-GUIDE CYLINDER

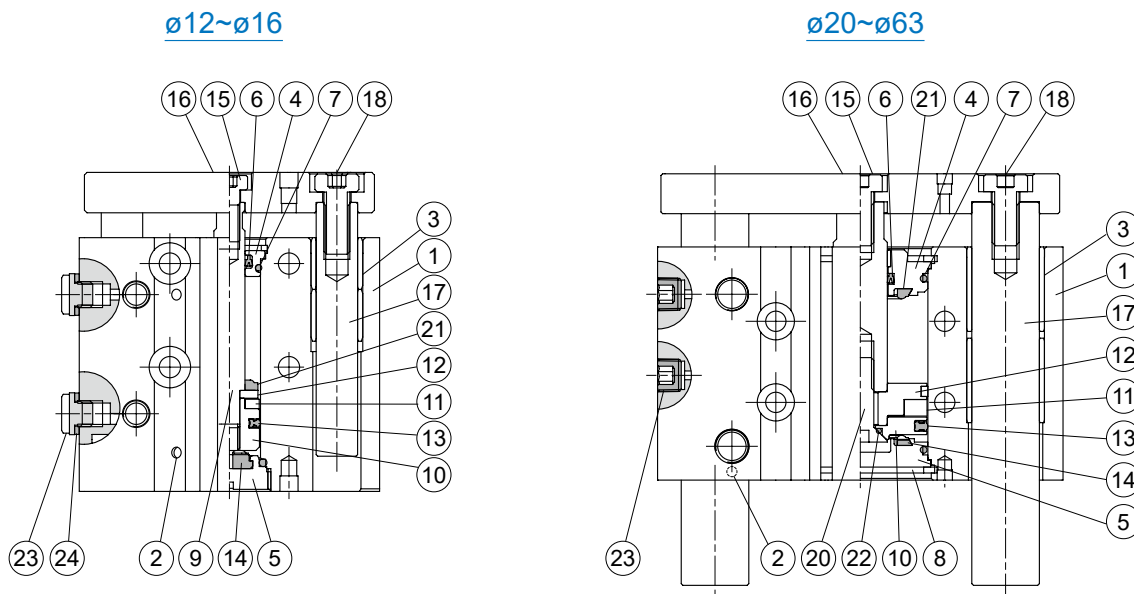

Material

No.	Tube I.D. Part name	12	16	20	25	32	40	50	63	Qty	Repair kits (inclusion)
1	Body	Aluminum alloy								1	
2	Ball	Stainless steel								1~3	
3	Slide bush	Bronze alloy						Bearing alloy		4	
4	Rod cover	Aluminum alloy								1	
5	Head cover	(*1)	Carbon steel				Aluminum alloy			1	
6	Rod packing	NBR								1	●
7	Cover ring	NBR								2	●
8	Snap ring	Spring steel								2	
9	Piston rod	Stainless steel			Carbon steel					1	
10	Piston	Aluminum alloy								1	
11	Magnet ring	Magnet material								1	
12	Magnet holder	Stainless steel				Aluminum alloy				1	
13	Piston packing	NBR								1	●
14	Head cushion	NBR								1	●
15	Bolt	SCM								1	
16	Plate	Carbon steel								1	
17	Guide rod	Carbon steel								2	
18	Screw	SCM								2	
19	Rod bush	—					Bearing alloy			1	
20	Piston bolt	—					SCM			1	
21	Rod cushion	NBR								1	●
22	Piston gasket	—					NBR			1	●
23	Screw	Bronze alloy		Carbon steel (*2)						2	
24	Washer	PET		—						2	

*1. Aluminum alloy *2. The material changes into bronze alloy when the part thread is BSPF. (JISPF)

Order example of repair kits

Tube I.D.	Repair kits
ø12	PS-MCGS-12
ø16	PS-MCGS-16
ø20	PS-MCGS-20
ø25	PS-MCGS-25
ø32	PS-MCGS-32
ø40	PS-MCGS-40
ø50	PS-MCGS-50
ø63	PS-MCGS-63

Cylinder weight Unit: g

Model	Basic weight MCGS-03	Stroke 5mm MCGS-03
Tube I.D.		
ø12	191	21
ø16	283	28
ø20	450	45
ø25	670	63
ø32	1,210	90
ø40	1,474	88
ø50	2,540	140
ø63	3,295	151

MCGS-07 Inside structure & Parts list



TWIN-GUIDE CYLINDER

mindman

ø12~ø16

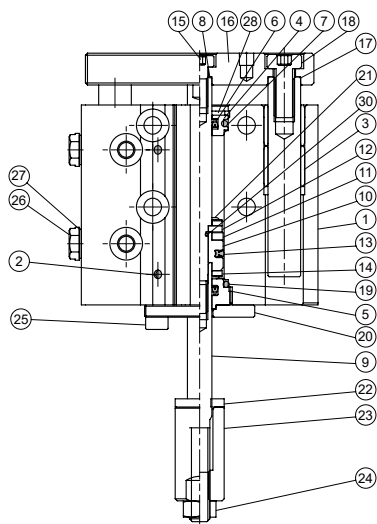

ø20~ø32

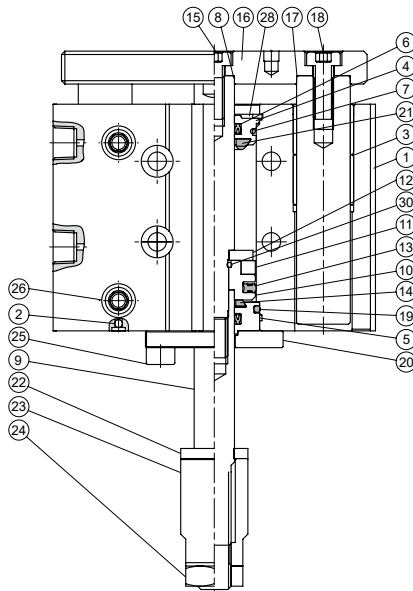

ø40~ø63

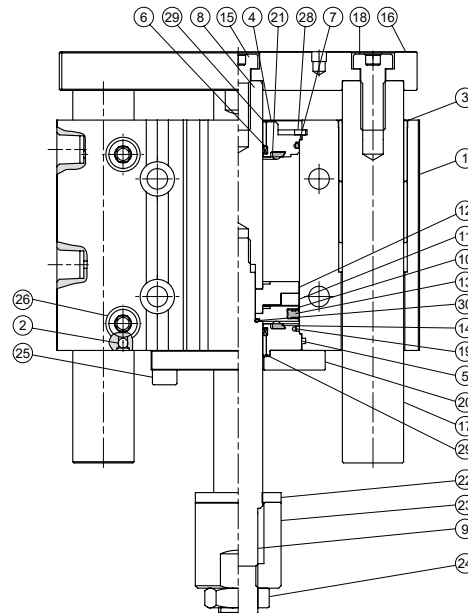

Material

No.	Tube I.D. Part name	12	16	20	25	32	40	50	63	Q'y	Repair kits (inclusion)	
1	Body	Aluminum alloy								1		
2	Ball	Stainless steel								1~3		
3	Slide bush	Bronze alloy						Bearing alloy		4		
4	Rod cover #1	Aluminum alloy								1		
5	Rod cover #2	Aluminum alloy								1		
6	Rod packing	NBR								2	●	
7	Cover ring #1	NBR								1	●	
8	Piston rod #1	Stainless steel	Carbon steel								1	
9	Piston rod #2	Stainless steel	Carbon steel								1	
10	Piston	Aluminum alloy								1		
11	Magnet ring	Magnet material								1		
12	Magnet holder	Stainless steel				Aluminum alloy				1		
13	Piston packing	NBR								1	●	
14	Head cushion	NBR								1	●	
15	Bolt	SCM								1		
16	Plate	Carbon steel								1		
17	Guide rod	Carbon steel								2		
18	Bolt	SCM								2		
19	Cover ring #2	NBR								1	●	
20	FBC board	Carbon steel								1		
21	Rod cushion	NBR								1	●	
22	Gasket	PU								1		
23	Adjustable nut	Carbon steel								1		
24	Nut	Carbon steel								1		
25	Bolt	Stainless steel	SCM								2	
26	Screw	Bronze alloy	Carbon steel (*)								2	
27	Washer	PET	—								2	
28	Snap ring	Spring steel								1		
29	Bush	—						Bearing alloy		2		
30	Piston gasket	NBR								1	●	

Order example of repair kits

Tube I.D.	Repair kits
ø12	PS-MCGS-2-12
ø16	PS-MCGS-2-16
ø20	PS-MCGS-2-20
ø25	PS-MCGS-2-25
ø32	PS-MCGS-2-32
ø40	PS-MCGS-2-40
ø50	PS-MCGS-2-50
ø63	PS-MCGS-2-63

* The material changes into bronze alloy when the part thread is BSPF. (JISPF)

MCGS-23 Inside structure & Parts list

TWIN-GUIDE CYLINDER



ø12~ø16

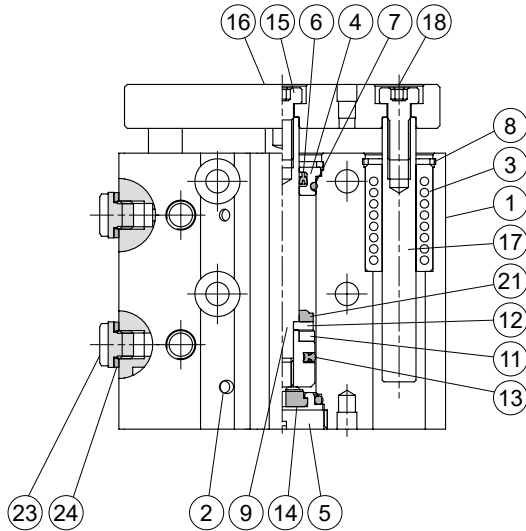

ø20~ø63

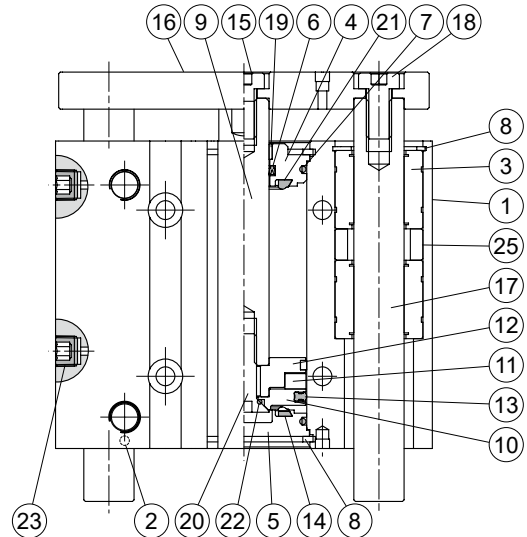

Material

No.	Tube I.D. Part name	12	16	20	25	32	40	50	63	Q'y	Repair kits (inclusion)	
1	Body	Aluminum alloy								1		
2	Ball	Stainless steel								1~3		
3	Linear bearing	—								2 or 4		
4	Rod cover	Aluminum alloy								1		
5	Head cover	(*1)	Carbon steel			Aluminum alloy				1		
6	Rod packing	NBR								1	●	
7	Cover ring	NBR								2	●	
8	Snap ring	Spring steel								2		
9	Piston rod	Stainless steel			Carbon steel					1		
10	Piston	Aluminum alloy								1		
11	Magnet ring	Magnet material								1		
12	Magnet holder	Stainless steel			Aluminum alloy					1		
13	Piston packing	NBR								1	●	
14	Head cushion	NBR								1	●	
15	Bolt	SCM								1		
16	Plate	Carbon steel								1		
17	Guide rod	Special steel								2		
18	Screw	SCM								2		
19	Rod bush	—			Bearing alloy					1		
20	Piston bolt	—			SCM					1		
21	Rod cushion	NBR								1	●	
22	Piston gasket	—			NBR					1	●	
23	Screw	Bronze alloy	Carbon steel (*2)								2	
24	Washer	PET	—								2	
25	Collar (*3)	Aluminum alloy	Carbon steel								2	

Order example of repair kits

Tube I.D.	Repair kits
ø12	PS-MCGS-12
ø16	PS-MCGS-16
ø20	PS-MCGS-20
ø25	PS-MCGS-25
ø32	PS-MCGS-32
ø40	PS-MCGS-40
ø50	PS-MCGS-50
ø63	PS-MCGS-63

Cylinder weight

Unit: g

Model	Basic weight MCGS-23	Stroke 5mm MCGS-23
Tube I.D.		
ø12	211	18
ø16	260	30
ø20	470	45
ø25	740	60
ø32	1,170	85
ø40	1,300	98
ø50	2,360	150
ø63	3,010	168

*1. Aluminum alloy *2. The material changes into bronze alloy when the part thread is BSPF. (JISPF) *3. Use for stroke 101 or more.

MCGS-27 Inside structure & Parts list

TWIN-GUIDE CYLINDER



ø12~ø16

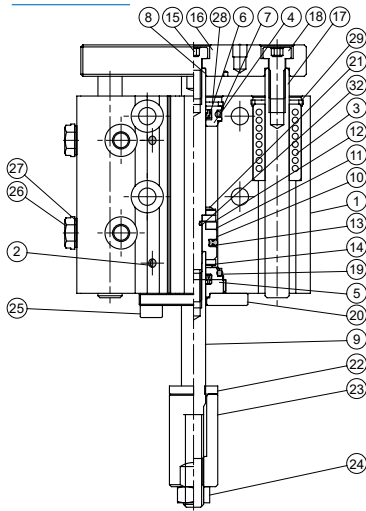

ø20~ø32

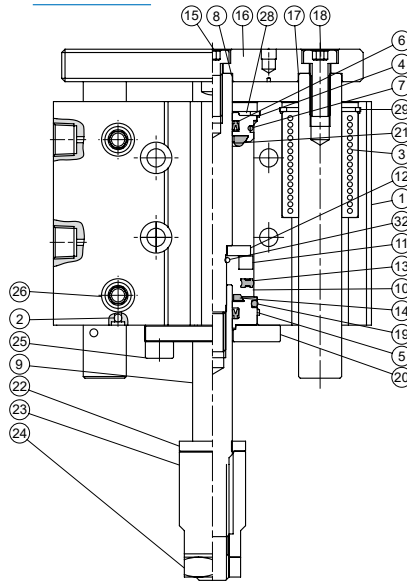

ø40~ø63

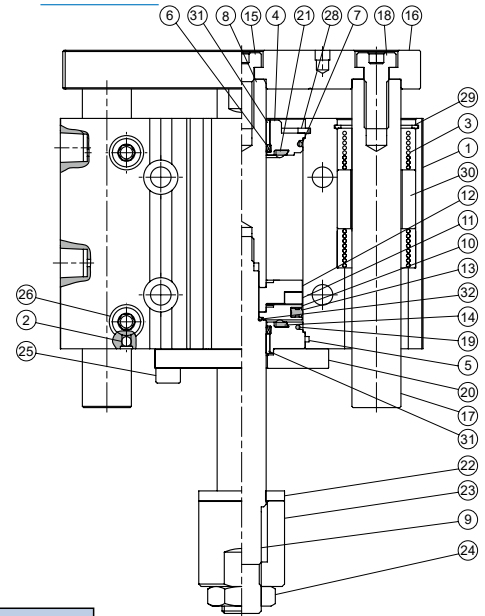

Material

No.	Tube I.D. Part name	12	16	20	25	32	40	50	63	Q'y	Repair kits (inclusion)	
1	Body	Aluminum alloy									1	
2	Ball	Stainless steel									1~3	
3	Linear bearing	—									2 or 4	
4	Rod cover #1	Aluminum alloy									1	
5	Rod cover #2	Aluminum alloy									1	
6	Rod packing	NBR									2	●
7	Cover ring #1	NBR									1	●
8	Piston rod #1	Stainless steel		Carbon steel						1		
9	Piston rod #2	Stainless steel		Carbon steel						1		
10	Piston	Aluminum alloy									1	
11	Magnet ring	Magnet material									1	
12	Magnet holder	Stainless steel			Aluminum alloy						1	
13	Piston packing	NBR									1	●
14	Head cushion	NBR									1	●
15	Bolt	SCM									1	
16	Plate	Carbon steel									1	
17	Guide rod	Special steel									2	
18	Bolt	SCM									2	
19	Cover ring #2	NBR									1	●
20	FBC board	Carbon steel									1	
21	Rod cushion	NBR									1	●
22	Gasket	PU									1	
23	Adjustable nut	Carbon steel									1	
24	Nut	Carbon steel									1	
25	Bolt	Stainless steel		SCM						2		
26	Screw	Bronze alloy		Carbon steel (*2)						2		
27	Washer	PET		—						2		
28	Snap ring #1	Spring steel									1	
29	Snap ring #2	Spring steel									2	
30	Collar (*1)	Aluminum alloy		Carbon steel						2		
31	Bush			—			Bearing alloy			2		
32	Piston gasket	NBR									1	●

Order example of repair kits

Tube I.D.	Repair kits
ø12	PS-MCGS-2-12
ø16	PS-MCGS-2-16
ø20	PS-MCGS-2-20
ø25	PS-MCGS-2-25
ø32	PS-MCGS-2-32
ø40	PS-MCGS-2-40
ø50	PS-MCGS-2-50
ø63	PS-MCGS-2-63

*1. Use for stroke 101 or more.

*2. The material changes into bronze alloy when the part thread is BSPF. (JISPF)

MCGS-03/23 Dimensions $\phi 12\sim\phi 32$

TWIN-GUIDE CYLINDER

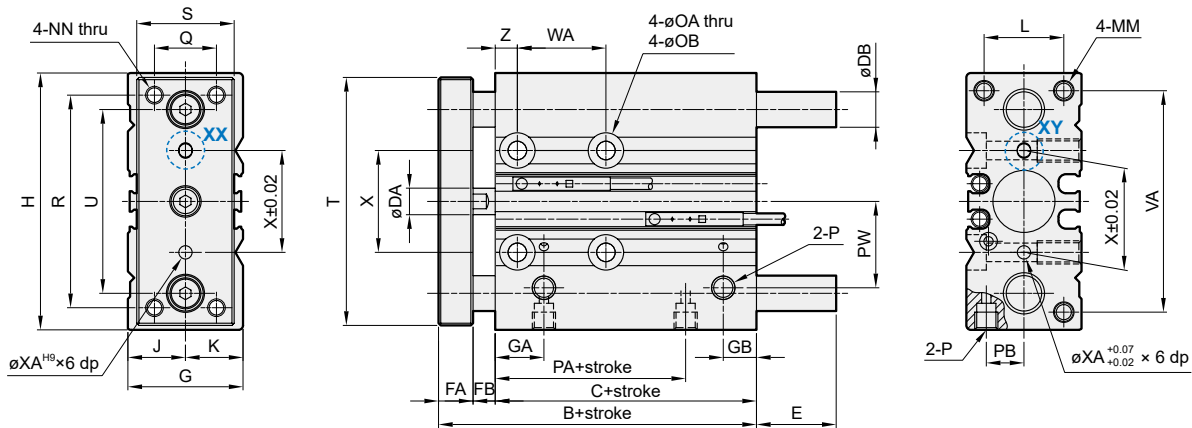
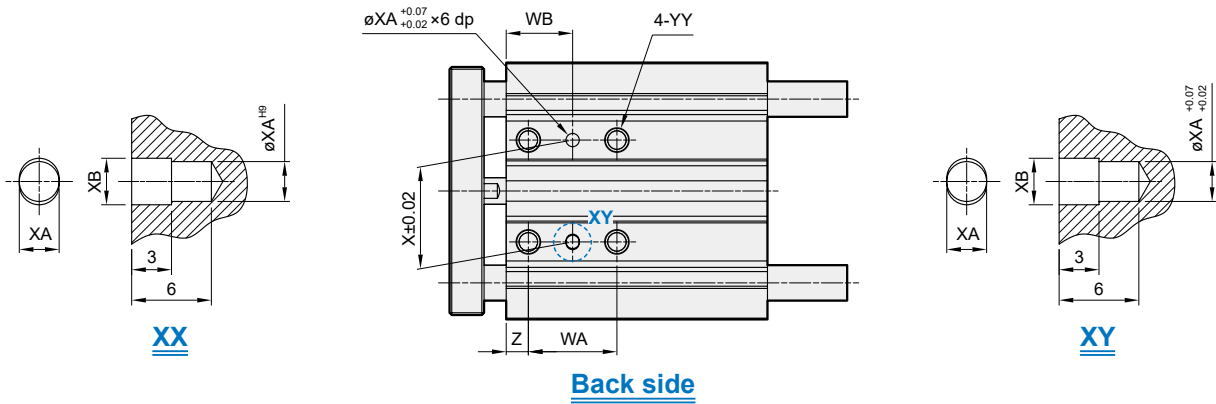

MCGS-03 / MCGS-23

Code Tube I.D.	B	C	DA	DB		FA	FB	G	GA	GB	H	J	K	L	MM	NN	OA	OB	P	PA	PB
				03 type	23 type																
12	42	29	6	8	6	8	5	26	11	15 ^(*1)	58	13	13	18	M4×0.7×10dp	M4×0.7	4.3	8.0×4.5dp	M5×0.8	14	8.5
16	46	33	8	10	8	8	5	30	11	18 ^(*2)	64	15	15	22	M5×0.8×12dp	M5×0.8	4.3	8.0×4.5dp	M5×0.8	15	10.0
20	53	37	10	12	10	10	6	36	10.5	8.5	85	17	19	24	M5×0.8×13dp	M5×0.8	5.2	9.5×5.5dp	Rc1/8	12.5	11.5
25	53.5	37.5	12	16	13	10	6	42	11.5	9	96	21	21	30	M6×1.0×15dp	M6×1.0	5.2	9.5×5.5dp	Rc1/8	12.5	13.5
32	59.5	37.5	16	20	16	12	10	51	12.5	9	116	26	25	34	M8×1.25×20dp	M8×1.25	6.6	11.0×7.5dp	Rc1/8	7	16.0

Code Tube I.D.	PW	Q	R	S	T	U	VA	X	XA	XB	YY	Z
12	18	14	48	22	56	41.5	50	23	3	3.5	M5×0.8×10dp	5
16	19	16	54	25	62	46	56	24	3	3.5	M5×0.8×10dp	5
20	25	18	70	30	81	55	72	28	3	3.5	M6×1.0×12dp	17
25	28.5	26	78	38	91	65	82	34	4	4.5	M6×1.0×12dp	17
32	34	30	96	44	110	80	98	42	4	4.5	M8×1.25×16dp	21

Code Tube I.D.	WA					WB				
	~39st	40~100st	125~200st	201st~300st	301st~	~39st	40~100st	125~200st	201~300st	301st~
12	20	40	110	200	—	15	25	60	105	—
16	24	44	110	200	—	17	27	60	105	—
20	24	44	120	200	300	29	39	77	117	167
25	24	44	120	200	300	29	39	77	117	167

Code Tube I.D.	WA					WB				
	25~49st	50~100st	125~200st	201st~300st	301st~	25~49st	50~100st	125~200st	201~300st	301st~
32	24	48	124	200	300	33	45	83	121	171

MCGS-03

Code Tube I.D.	E		
	10~50st	51~100st	101st~
12	—	18.5	43
16	—	18.5	49
	10~50st	51~200st	201st~
20	—	31.5	69
25	—	31.5	68.5
32	37.5	42.5	80.5

MCGS-23

Code Tube I.D.	E			
	10~30st	31~100st	101st~	
12	1	13	43	
16	3	19	49	
	20~30st	31~100st	101~200st	201st~
20	10	27	51	69
25	16	32	51	68.5
32	21.5	38.5	58.5	80.5

*1. When stroke length is equal to 19mm or less, GB=7.5 mm
 *2. When stroke length is equal to 19mm or less, GB=9 mm

MCGS-03/23 Dimensions $\phi 40\sim\phi 63$

TWIN-GUIDE CYLINDER

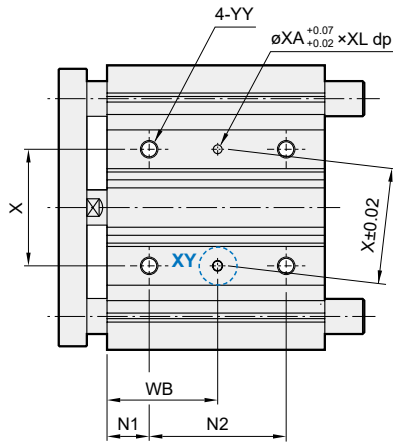
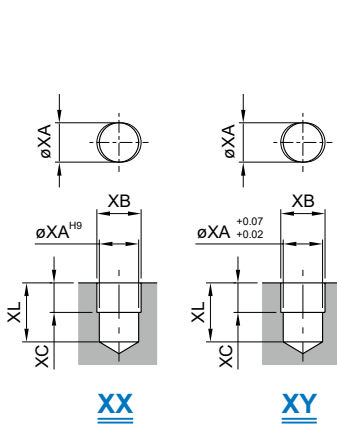

Back side

T slot for hexagon head bolt

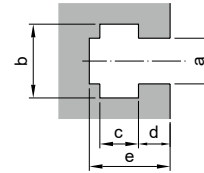

T slot for hexagon head bolt

Code Tube I.D.	a	b	c	d	e
40	6.5	10.5	5.5	4	11
50	8.5	13.5	7.5	4.5	13.5
63	11	17.8	10	7	18.5

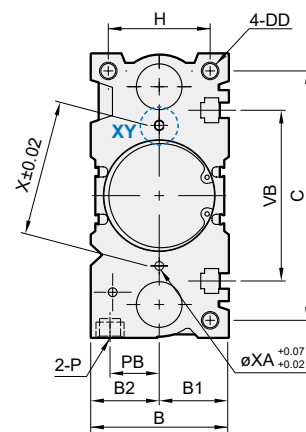
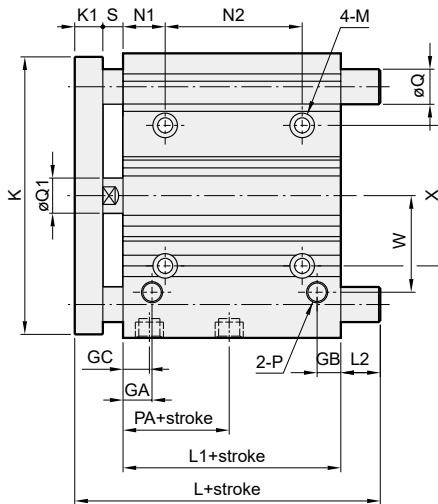
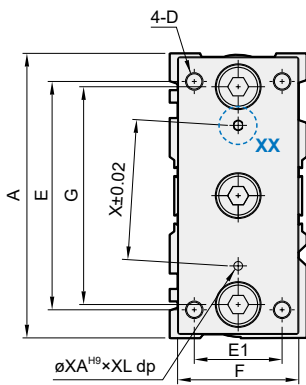

MCGS-03 / MCGS-23

Code Tube I.D.	A	B	B1	B2	C	D	DD	E	E1	F	G	GA	GB	GC	H	K	K1	L1	M	N1	P
40	120	54	27	27	106	M8×1.25	M8×1.25×20 dp	104	30	44	86	14	10	14	40	118	12	44	$\phi 6.8$ thru, $\phi 11 \times 7.5$ dp	22	Rc1/8
50	148	64	32	32	130	M10×1.5	M10×1.5×22 dp	130	40	60	110	14	11	12	46	146	16	44	$\phi 8.6$ thru, $\phi 14 \times 9$ dp	24	Rc1/4
63	162	78	39	39	142	M10×1.5	M10×1.5×22 dp	130	50	70	124	16.5	13.5	16.5	58	158	16	49	$\phi 8.6$ thru, $\phi 14 \times 9$ dp	24	Rc1/4

Code Tube I.D.	PA	PB	Q1	S	VB	W	X	XA	XB	XC	XL	YY	N2					WB				
													25st	50,75,100st	101st~200st	201~300st	301~400st	25st	50,75,100st	101st~200st	201~300st	301~400st
40	13	18	16	10	72	38	50	$\phi 4$	4.5	3	6	M8×1.25×16 dp	24	48	124	200	300	34	46	84	122	172
50	9	21.5	20	12	92	47	66	$\phi 5$	6	4	8	M10×1.5×20 dp	24	48	124	200	300	36	48	86	124	174
63	14	28	20	12	110	55	80	$\phi 5$	6	4	8	M10×1.5×20 dp	28	52	128	—	—	38	50	88	—	—

MCGS-03

Code Tube I.D.	L		L2			Q
	25,50st	51st~	25,50st	51~200st	201~400st	
40	97	102	31	36	63.5	$\phi 20$
50	106.5	118	34.5	46	78.5	$\phi 25$
63	106.5	118	29.5	41	—	$\phi 25$

MCGS-23

Code Tube I.D.	L			L2				Q
	25,50st	75,100st	101st~	25,50st	75,100st	101~200st	201~400st	
40	81	98	118	15	32	52	72.5	$\phi 16$
50	93	114	134	21	42	62	87.5	$\phi 20$
63	93	114	134	16	37	57	—	$\phi 20$

MCGS-07/27 Dimensions $\varnothing 12\sim\varnothing 20$

TWIN-GUIDE CYLINDER

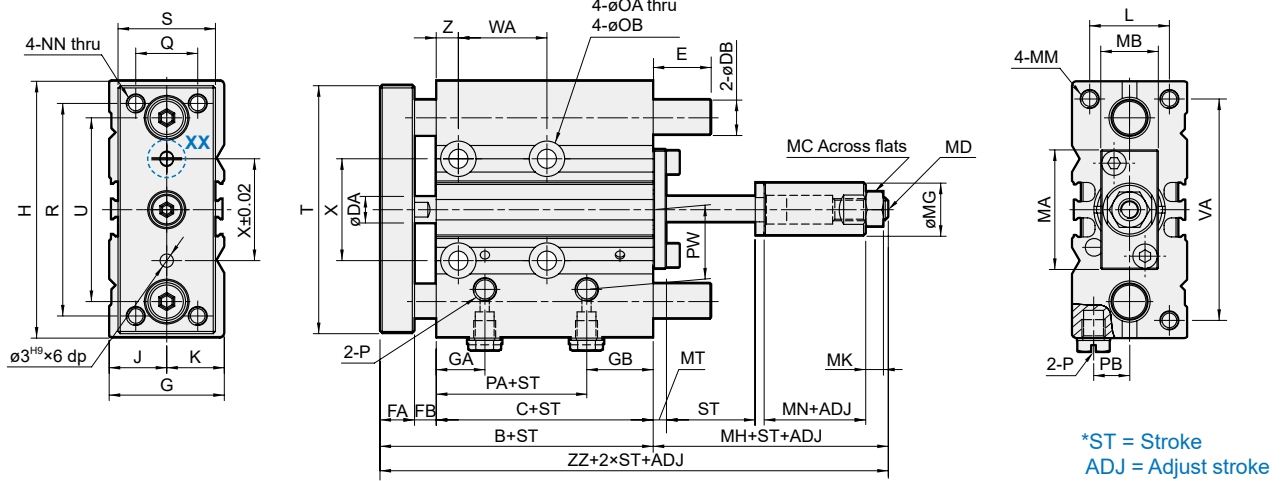
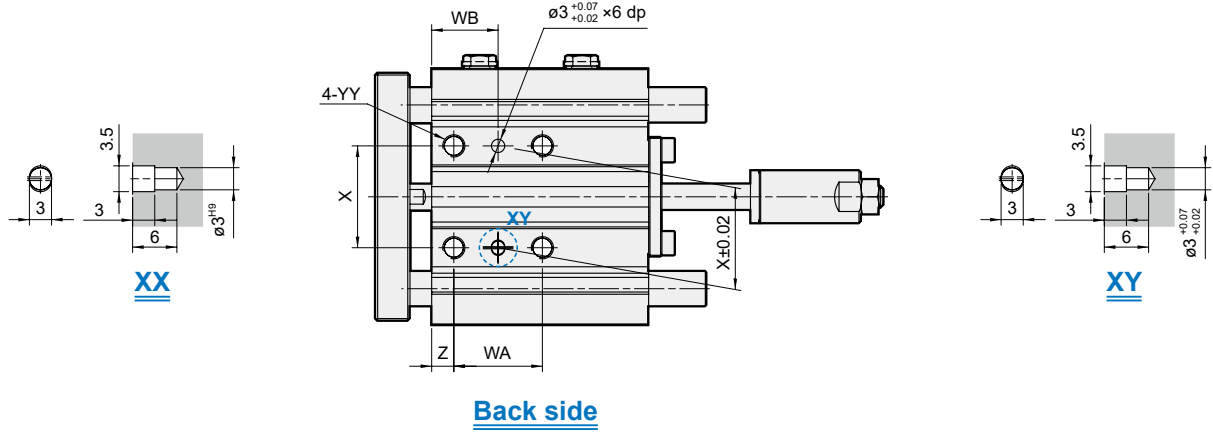

MCGS-07 / MCGS-27

Code Tube I.D.	B	C	DA	DB		FA	FB	G	GA	GB	H	J	K	L	MA	MB	MC	MD	MG	MH	MK	MN	MM	MT
				07 type	27 type																			
12	42	29	6	8	6	8	5	26	11	15 ^(*1)	58	13	13	18	27	13	8	M5×0.8	12	23	4	13	M4×0.7×10dp	3
16	46	33	8	10	8	8	5	30	11	18 ^(*2)	64	15	15	22	28	16	10	M6×1.0	15	26	5	15	M5×0.8×12dp	3
20	53	37	10	12	10	10	6	36	10.5	8.5	85	17	19	24	33	22	13	M8×1.25	20	26	5	12	M5×0.8×13dp	4

Code Tube I.D.	NN	OA	OB	P	PA	PB	PW	Q	R	S	T	U	VA	X	YY	Z	ZZ
12	M4×0.7	4.3	8×4.5dp	M5×0.8	14	8.5	18	14	48	22	56	41.5	50	23	M5×0.8×10dp	5	65
16	M5×0.8	4.3	8×4.5dp	M5×0.8	15	10.0	19	16	54	25	62	46	56	24	M5×0.8×10dp	5	72
20	M5×0.8	5.2	9.5×5.5dp	Rc1/8	12.5	11.5	25	18	70	30	81	55	72	28	M6×1.0×12dp	17	79

MCGS-07

Code Tube I.D.	WA				WB					
	10~39st	40~100st	125~200st	201st~300st	10~39st	40~100st	125~200st	201~300st		
12	20	40	110	200	15	25	60	105		
16	~39st	40~100st	125~200st	201st~300st	~39st	40~100st	125~200st	201st~300st		
	24	44	110	200	17	27	60	105		
20	~39st	40~100st	125~200st	201st~300st	301st~	~39st	40~100st	125~200st	201st~300st	301st~
	24	44	120	200	300	29	39	77	117	167

Code Tube I.D.	E		
	~50st	51~100st	101st~
12	0	18.5	43
16	10~50st	51~100st	101st~
	0	18.5	49
20	~50st	51~200st	201st~
	0	31.5	69

MCGS-27

Code Tube I.D.	E			
	~30st	31~100st	101st~	
12	1	13	43	
16	10~30st	31~100st	101st~	
	3	19	49	
20	20~30st	31~100st	101~200st	201st~
	10	27	51	69

*1. When stroke length is equal to 19mm or less, GB=7.5 mm
*2. When stroke length is equal to 19mm or less, GB=9 mm

MCGS-07/27 Dimensions $\varnothing 25 \sim \varnothing 63$

TWIN-GUIDE CYLINDER



Mindman

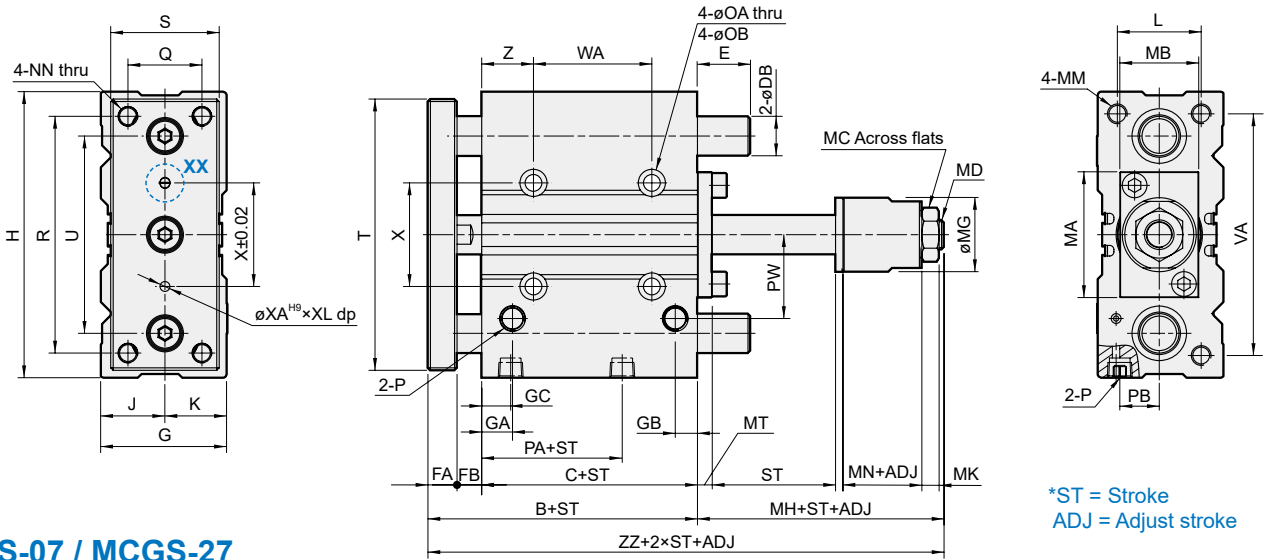
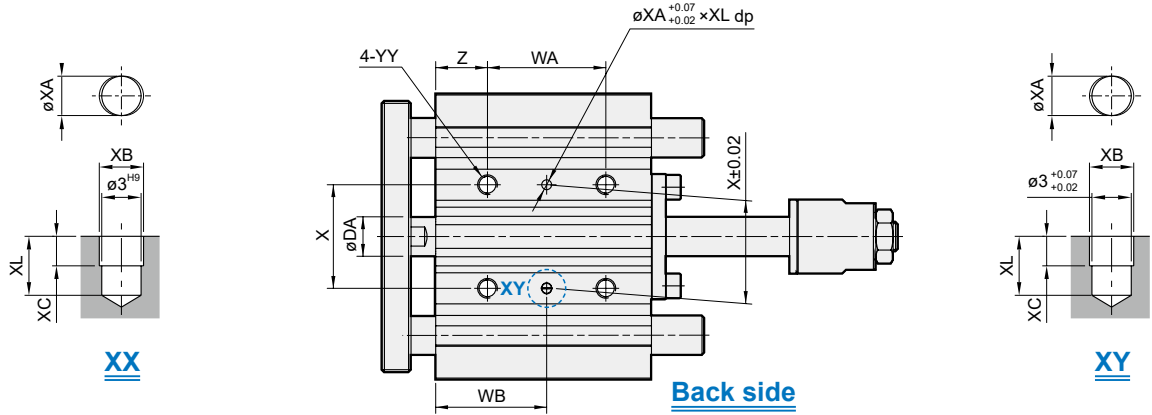

*ST = Stroke
ADJ = Adjust stroke

MCGS-07 / MCGS-27

Code Tube I.D.	B	C	DA	DB		FA	FB	G	GA	GB	GC	H	J	K	L	MA	MB	MC	MD	MG	MH	MK	MN	MM	MT
				07 type	27 type																				
25	53.5	37.5	12	16	13	10	6	42	11.5	9	11.5	96	21	21	30	41	25	17	M10×1.25	20	27	6	12	M6×1.0×15dp	5
32	59.5	37.5	16	20	16	12	10	51	12.5	9	12.5	116	26	25	34	51	32	19	M12×1.25	30	30	7	12	M8×1.25×20dp	6
40	66	44	16	20	16	12	10	54	14	10	14	120	27	27	40	60	32	19	M12×1.25	30	30	7	12	M8×1.25×20dp	6
50	72	44	20	25	20	16	12	64	14	11	12	148	32	32	46	71	38	24	M16×1.5	35	38	8	15	M10×1.5×22dp	8
63	77	49	20	25	20	16	12	78	16.5	13.5	16.5	162	39	39	58	84	50	24	M16×1.5	35	38	8	15	M10×1.5×22dp	8

Code Tube I.D.	NN	OA	OB	P	PA	PB	PW	Q	R	S	T	U	VA	X	XA	XB	XC	XL	YY	Z	ZZ
25	M6×1.0	5.2	9.5×5.5dp	Rc1/8	12.5	13.5	28.5	26	78	38	91	65	82	34	4	4.5	3	6	M6×1.0×12dp	17	80.5
32	M8×1.25	6.6	11×7.5dp	Rc1/8	7	16	34	30	96	44	110	80	98	42	4	4.5	3	6	M8×1.25×16dp	21	89.5
40	M8×1.25	6.8	11×7.5dp	Rc1/8	13	18	38	30	104	44	118	86	106	50	4	4.5	3	6	M8×1.25×16dp	22	96
50	M10×1.5	8.6	14×9dp	Rc1/4	9	21.5	47	40	130	60	146	110	130	66	5	6	4	8	M10×1.5×20dp	24	110
63	M10×1.5	8.6	14×9dp	Rc1/4	14	28	55	50	130	70	158	124	142	80	5	6	4	8	M10×1.5×20dp	24	115

Code Tube I.D.	WA					WB						
	~39st	40~100st	125~200st	201st~300st	301st~	~39st	40~100st	125~200st	201~300st	301st~		
25	24	44	120	200	300	29	39	77	117	167		
32	~49st	50~100st	125~200st	201st~300st	301st~	~49st	50~100st	125~200st	201st~300st	301st~		
	24	48	124	200	300	33	45	83	121	171		
40	~49st	50~69st	70~100st	125~200st	201st~300st	301st~	~49st	50~69st	70~100st	125~200st	201st~300st	301st~
	24	48	48	124	200	300	34	46	46	84	122	172
50	~49st	50~69st	70~100st	125~200st	201st~300st	301st~	~49st	50~69st	70~100st	125~200st	201st~300st	301st~
	24	48	48	124	200	300	36	48	48	86	124	174
63	~49st	50~100st	125st~				~49st	50~100st	125st~			
	28	52	128			38	50	88				

MCGS-07

Code Tube I.D.	E		
	~50st	51~200st	201st~
25	0	31.5	68.5
32	37.5	42.5	80.5
40	31	36	63.5
50	34.5	46	78.5
63	~50st	51st~	
	29.5	41	

MCGS-27

Code Tube I.D.	E			
	20~30st	31~100st	101~200st	201st~
25	16	32	51	68.5
	~20~50st	51~100st	101~200st	201st~
32	21.5	38.5	58.5	80.5
	~69st	70~100st	101~200st	201st~
40	15	32	52	72.5
	~69st	70~100st	101st~	
50	21	42	62	87.5
	~69st	70~100st	101st~	
63	16	37	57	
	~69st	70~100st	101st~	