



Ultra Small Push-In Fitting Type for Pneumatic Piping Tube Fitting Mini Series

- Ultra Small Push-In Fitting for General Pneumatic Piping.
- 40% Miniaturized compared to Standard Type.



- Easy Tube Release with Oval Release-Ring.

- $\phi 1.8$ Tube Size. The Industry's First Smallest Push-In Fitting. Suitable for Small Actuator Piping



Miniature cylinder

Miniature Gripper

Miniature Solenoid Valve

- Optional Selection of Body Color (light-gray) and Clean-Room Package.

Fluorine-based grease is used on O-ring for clean-room package.
Products are packed in a clean room equivalent to ISO class 6.

Model Designation (Example)

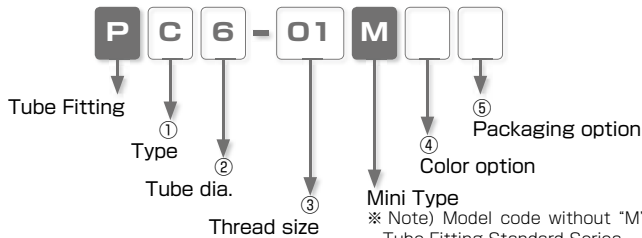

① Type

Code	Type	Code	Type	Code	Type	Code	Type
C	Straight	OC	Inner Hex. Straight	CC	Cartridge	L	Elbow
LL	Long Elbow	LH	45° Elbow	B	Branch Tee	D	Run Tee
OL	Hex. Holed Banjo	OLL	Hex. Holed Long Banjo	U	Union Straight	G	Unequal Union Straight
V	Union Elbow	E	Union Tee	EG	Unequal Union Tee	Y	Union Y
W	Unequal Union Y	M	Bulkhead Union	ZA	Cross A	ZB	Cross B
ZC	Cross C	GJ	Unequal Plug-in Straight	LJ	Plug-in Elbow	LGJ	Unequal Plug-in Elbow
LHJ	45° Plug-in Elbow	YJ	Plug-in Y	WJ	Unequal Plug-in Y	CF	Female Straight
F	Extension Screw Adaptor	IJ	Union Stem	PF	Cap	P	Plug

② Tube dia. (※ In case that ② indicates thread size, select thread size from table ③)

Tube dia.	mm size				inch size			
Code	180	3	4	6	1/8	5/32	3/16	1/4
Size (mm)	ø1.8	ø3	ø4	ø6	ø3.2	ø3.97	ø4.76	ø6.35

③ Thread size (※ In case that ③ indicates tube dia., select tube dia. from table ②)

Thread size	Metric thread (mm)			Taper pipe thread			Cartridge size (mm)	
Code	M3	M5	M6	01	02	03	M6	M8
Size	M3 × 0.5	M5 × 0.8	M6 × 1	R1/8	R1/4	R3/8	M6 × 0.75	M8 × 0.75

Thread size	UNF thread (mm)	NPT thread
Code	U10U	N1U
Size	10-32UNF	NPT1/8

※ The unit of wrench size is inch (the code suffix is "U").

④ Color option ⑤ Packaging option

Code	④ : Color option		⑤ : Packaging option	
	No code	W	No code	C
Specification	Standard spec.	Light-gray spec.	Standard package	Clean-room package
Release-ring color	Black	Light-gray	④ : Selected color	Light-blue (※ 1)
Resin body color	Black	Light-gray	④ : Selected color	Light-blue

※ 1. When "W" is selected on ④ Color option, body color is light-gray.

※ 2. Release-ring color is white for inch-size products.

Specifications

Fluid medium	Air
Max. operating pressure	1.0MPa
Max. vacuum	-100kPa
Operating temp. range	0 ~ 60°C (No freezing)

Construction (Elbow: PL)

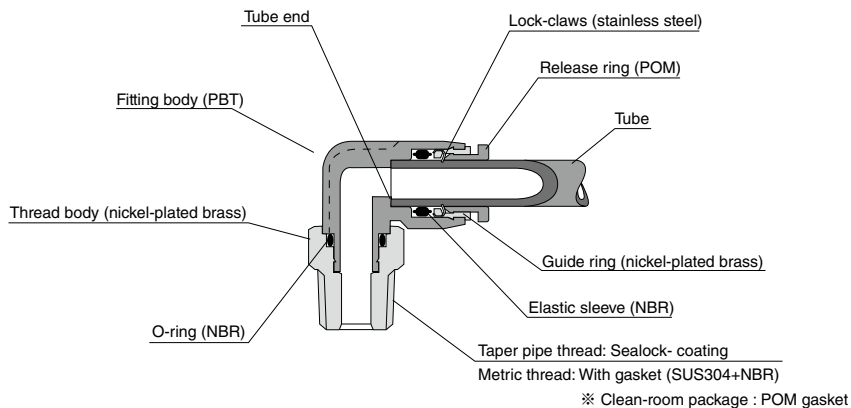

- ※ M3 Thread: Thread body is nickel-plated free-cutting steel.
- ø1.8 fitting: Thread body is special stainless steel equivalent to SUS303.

△ Detailed Safety Instructions

Before using PISCO products, be sure to read "Safety Instructions" and "Safety Instruction Manual" on page 23 to 27 and "Common Safety Instructions for Fittings" on page 33 to 35.

Caution (Clean-room package)

1. As for Push-In Fitting, the functional part where tube is inserted may slightly slide due to an internal pressure change and this may generate dusts. Avoid using the fitting in the clean room of ISO class from 1 to 5. Under the vibrating condition, check the amount of dust generated from the fitting and tubes by using actual facilities.

Standard Size List

Connection: Thread ⇔ Tube

Type	Page	Thread size	Tube O.D.						
			1.8	3	4	6	1/8	5/32	1/4
PC Straight	P.90	M3 × 0.5	●	●	●	●	●	●	
		M5 × 0.8	●	●	●	●	●	●	
		M6 × 1	●	●	●	●	●	●	
		R1/8			●	●	●	●	●
		R1/4				●	●	●	●
R3/8				●					
POC Inner Hex. Straight	P.91	M3 × 0.5	●	●	●	●	●	●	
		M5 × 0.8	●	●	●	●	●	●	
		M6 × 1	●	●	●	●	●	●	
		R1/8			●	●	●	●	●
PCC Cartridge	P.91	M6 × 0.75	●	●	●	●	●	●	
		M8 × 0.75			●				
PL Elbow	P.93	M3 × 0.5	●	●	●	●	●	●	
		M5 × 0.8	●	●	●	●	●	●	
		M6 × 1	●	●	●	●	●	●	●
		R1/8			●	●	●	●	●
		R1/4				●	●	●	●
R3/8				●					
PLL Long Elbow	P.94	M3 × 0.5	●	●	●	●	●	●	
		M5 × 0.8	●	●	●	●	●	●	●
		M6 × 1	●	●	●	●	●	●	●
		R1/8			●	●	●	●	●

Type	Page	Thread size	Tube O.D.						
			1.8	3	4	6	1/8	5/32	1/4
PLH 45° Elbow	P.95	M3 × 0.5		●	●	●	●	●	
		M5 × 0.8		●	●	●	●	●	
		M6 × 1			●	●	●	●	●
		R1/8			●	●	●	●	●
		R1/4				●	●	●	●
PB Branch Tee	P.99	M3 × 0.5	●	●	●	●	●	●	●
		M5 × 0.8	●	●	●	●	●	●	●
		M6 × 1	●	●	●	●	●	●	●
		R1/8			●	●	●	●	●
R1/4				●	●	●	●		
R3/8				●					
PD Run Tee	P.100	M3 × 0.5	●	●	●	●	●	●	●
		M5 × 0.8	●	●	●	●	●	●	●
		M6 × 1	●	●	●	●	●	●	●
		R1/8			●	●	●	●	●
R1/4				●	●	●	●		
R3/8				●					
POL Hex. Holed Banjo	P.96	M5 × 0.8		●	●	●	●	●	
POLL Hex. Holed Long Banjo	P.96	M5 × 0.8		●	●	●	●	●	
PCF Female Straight	P.92	M3 × 0.5	●	●	●	●	●	●	
		M5 × 0.8			●	●	●	●	

Connection: Tube ⇔ Tube (Equal dia.)

Type	Page	Tube O.D.				
		1.8	3	4	6	1/8
PU Union Straight	P.92	●	●	●	●	●
PV Union Elbow	P.95	●	●	●	●	●
PE Union Tee	P.101	●	●	●	●	●

Type	Page	Tube O.D.				
		1.8	3	4	6	1/8
PY Union Y	P.102		●	●	●	●
PM Bulkhead Union	P.105		●	●	●	●
PZA Cross A	P.104		●	●	●	●

Connection: Tube ⇔ Tube (Unequal dia.)

Type	Page	Tube O.D.1 (mm)	Tube O.D.2							
			1.8	3	4	6	1/8	5/32	3/16	1/4
PG Unequal Union Straight	P.92	3	●							
		4	●	●					●	
		6		●	●				●	
		1/4							●	
PEG Unequal Union Tee	P.101	3	●		●					
		4		●		●			●	
		6			●		●			●
		1/8					●			●
		5/32								●

Type	Page	Tube O.D.1 (mm)	Tube O.D.2			
			3	4	1/8	5/32
PW Unequal Union Y	P.102	4	●			
		6		●		●
		1/8				●
		1/4				●
PZB Cross B	P.104	4	●			●
		6		●		●
		1/8				●
PZC Cross C	P.105	4	●			●
		6		●		●
		1/8				●

Connection: Tube ⇔ Fitting

Type	Page	Tube dia. (mm)	Tube O.D.							
			1.8	3	4	6	1/8	5/32	3/16	1/4
PGU Unequal Plug-in Straight	P.98	3		●	●	●	●	●		
		4		●	●	●	●	●		
		6			●	●	●	●	●	
		1/8					●	●	●	●
		5/32						●	●	●
		3/16							●	●
		1/4								●
PLUJ Plug-in Elbow	P.97	3		●						
		4			●					
		6				●				
		1/8					●			
		5/32						●		
		3/16							●	
1/4								●		

Type	Page	Tube dia. (mm)	Tube O.D.						
			1.8	3	4	6	1/8	5/32	3/16
PLGU Unequal Plug-in Elbow	P.97	3		●	●	●	●	●	
		4		●	●	●	●	●	
		6			●	●	●	●	●
		1/8					●	●	●
		5/32						●	●
		3/16							●
1/4								●	
PLHU 45° Plug-in Elbow	P.98	4			●				
		6				●			
		1/8					●		
PYU Plug-in Y	P.103	3		●					
		4			●				
		6				●			
		1/8					●		
PWU Unequal Plug-in Y	P.103	4		●					
		6			●				

Connection: Thread ⇔ Thread

Type	Page	Thread size1	Thread size 2(Inner thread)
PF Extension Screw Adaptor	P.106	M5 × 0.8 R1/8	M3 × 0.5
			●
			●

Connection: Fitting ⇔ Fitting

Type	Page		
PIJ Union Stem	P.106	3	1/8
		●	●

Plug

Type	Page	Tube O.D.(mm)	
PPF Cap	P.107	1.8	3
PP Plug	P.107	●	●

FITTING

CONTROLLER

VALVE

TUBE

MAKE-TO-ORDER PRODUCTS

Mini Series

Stainless Series

Chemical Series

PP Series

EG Series

Anti-siphon & Press Series

On/Off Control

Minimal Series

Stop Fitting Series

Rotary Series

Twist-Proof Fitting

Block and Connector

Coupling

Color Cap

How to insert and disconnect

1. How to insert and disconnect tubes

① Tube insertion

Insert a tube into Push-In Fitting up to the tube end. Lock-claws bite the tube and fix it automatically, then the elastic sleeve seals around the tube.

Refer to "2. Instructions for Tube Insertion" under "Common Safety Instructions for Fittings".

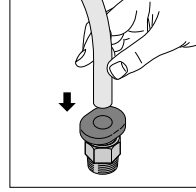

② Tube disconnection

The tube is disconnected by pushing release-ring to release Lock-claws.

Make sure to stop air supply before the tube disconnection.

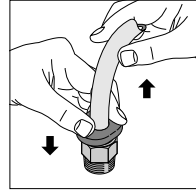

2. How to tighten thread

① Tightening thread

There are two ways to tighten a thread. Use a spanner or an impact wrench for a hexagonal-column. A hex key is for an inner hexagonal socket. Inner hexagonal type can save spaces.

Refer to "Table 2: Recommended tightening torque / Sealock color / Gasket materials" under "4. Instructions for Installing a fitting" in "Common Safety Instructions for Fittings".

Note) The recommended torque force of the model code "POC180-M3M" is 0.3N·m

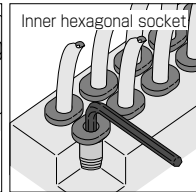
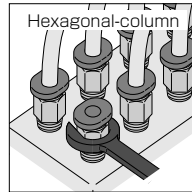

Release-ring dimension

The release-ring shape of Tube Fitting Mini Series is oval as the right picture shows in order to push it easily when removing tubes.

Check the dimension of release-ring in the catalog.

The release-ring of tube size $\phi 1.8$ is a round shape.

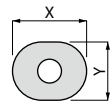

Applicable Tube and Related Products

Polyurethane Tube.....P.596

Nylon Tube.....P.608

Fluoresin Tube with clean-room package.....P.638

Polyurethane Tube with clean-room package.....P.642

PC Mini Straight
RoHS compliant

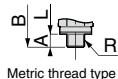
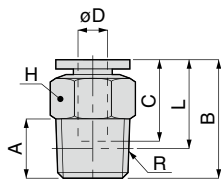

Metric thread type

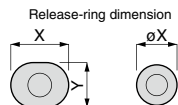

Release-ring dimension
øD: 3, 4, 6, 1/8, 5/32 øD: 1.8

Unit : mm

Model code	Tube O.D. øD	R	A	B	L	Tube end C	Hex. H	X (øX)	Y	Effective area (mm ²)	Weight (g)	CAD file name		
PC180-M3M(4)⑤	1.8	M3 × 0.5	2.5 [2.2]	12.1	9.6 [9.9]	8.4	5	4.8	-	0.7	1	PC180-M3M(ø5)		
PC180-M5M(4)⑤		M5 × 0.8	3 [3.2]	11.8	8.8 [8.6]		7					PC180-M5M(ø5)		
PC3-M3M(4)⑤	3	M3 × 0.5	2.5 [2.2]	13.1	10.6 [10.9]	9.4	5.5	7	6	0.7	1.1	PC3-M3M(ø5)		
PC3-M5M(4)⑤		M5 × 0.8	3 [3.2]	15.6	12.6 [12.4]		8					3.4	PC3-M5M(ø5)	
PC3-M6M(4)⑤		M6 × 1	3.9	16.6	12.7	10.9	8			9.8	7.8	3.7	6.7	PC3-M6M
PC3-01M(4)⑤		R1/8	8	15.6	11.6		10			2.9	6.3	PC3-01M		
PC4-M3M(4)⑤	4	M3 × 0.5	2.5 [2.2]	15.1	12.6 [12.9]	10.9	8	9.8	7.8	0.9	2.4	PC4-M3M(ø5)		
PC4-M5M(4)⑤		M5 × 0.8	3 [3.2]	15.6	12.6 [12.4]		8					3.8	3.2	PC4-M5M(ø5)
PC4-M6M(4)⑤		M6 × 1	3.9	16.6	12.7	10.9	8			9.8	7.8	6.3	3.6	PC4-M6M
PC4-01M(4)⑤		R1/8	8	15.6	11.6		10			6.4	6.6	PC4-01M		
PC4-02M(4)⑤	R1/4	11	17.3	11.3	14	6.1	14	PC4-02M						
PC6-M5M(4)⑤	6	M5 × 0.8	3 [3.2]	17	14 [13.8]	11.7	10	11.8	9.8	3.6	4.5	PC6-M5M(ø5)		
PC6-M6M(4)⑤		M6 × 1	3.9	18	14.1		10					6.3	4.8	PC6-M6M
PC6-01M(4)⑤		R1/8	8	17.6	13.6	11.7	10			11.8	9.8	6	6	PC6-01M
PC6-02M(4)⑤		R1/4	11	17.6	11.6		14			10.6	13	PC6-02M		
PC6-03M(4)⑤	R3/8	12	19.6	13.3	17	10.6	26	PC6-03M						
PC1/8-M3M(4)⑤	1/8	M3 × 0.5	2.5 [2.2]	15.1	12.6 [12.9]	10.9	8	9.8	7.8	0.9	2.5	PC1/8-M3M(ø5)		
PC1/8-M5M(4)⑤		M5 × 0.8	3 [3.2]	15.6	12.6 [12.4]		8					2.6	3.5	PC1/8-M5M(ø5)
PC1/8-M6M(4)⑤		M6 × 1	3.9	16.6	12.7	10.9	8			9.8	7.8	2.9	3.6	PC1/8-M6M
PC1/8-01M(4)⑤		R1/8	8	15.6	11.6		10			2.7	6.6	PC1/8-01M		
PC5/32-M3M(4)⑤	5/32	M3 × 0.5	2.5 [2.2]	15.1	12.6 [12.9]	10.9	8	9.8	7.8	0.9	2.4	PC5/32-M3M(ø5)		
PC5/32-M5M(4)⑤		M5 × 0.8	3 [3.2]	15.6	12.6 [12.4]		8					3.8	3.2	PC5/32-M5M(ø5)
PC5/32-M6M(4)⑤		M6 × 1	3.9	16.6	12.7	10.9	10			9.8	7.8	3.9	3.6	PC5/32-M6M
PC5/32-01M(4)⑤		R1/8	8	15.6	11.6		10			4.3	6.6	PC5/32-01M		
PC5/32-02M(4)⑤	R1/4	11	17.3	11.3	14	6.1	15	PC5/32-02M						

- ※ 1. ④ in Model code / Replaced with "W" for Light-gray color
- ※ 2. ⑤ in Model code / Replaced with "C" for Clean-room package
- ※ 3. "L" is a reference value for height dimension after tightening taper thread.
- ※ 4. Dimensions in [] are for clean-room package products
- ※ 5. Visit PISCO website for CAD data of clean-room package products.

FITTING
 CONTROLLER
 VALVE
 TUBE
 MAKE-TO-ORDER PRODUCTS
 Mini Series
 Stainless Series
 Chemical Series
 PP Series
 EG Series
 Anti-static & Pores Series
 The Computed Control
 Minimal Series
 Stop Fitting Series
 Rotary Series
 Twist-Proof Fitting
 Block and Connector
 Coupling
 Color Cap

90



Page for special specifications



3D CAD data is available at PISCO website.



CAD data is available at PISCO website.

Fitting Series

Tube Fitting Mini Series

FITTING



Inner Hex. Straight ϕD

RoHS compliant

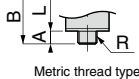
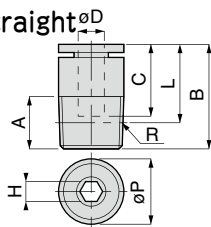

Release-ring dimension



ϕD : 3, 4, 6, 1/8, 5/32 ϕD : 1.8

Unit : mm

Model code	Tube O.D. ϕD	R	A	B	L	Tube end C	Hex. H	ϕP	X (ϕX)	Y	Effective area (mm^2)	Weight (g)	CAD file name
POC180-M3M (4)⑤	1.8	M3 × 0.5	2.5 [2.2]	12.1	9.6 [9.9]	8.4	1.3	5	4.8	—	0.7	0.9	POC180-M3M(4)⑤
POC3-M3M (4)⑤	3	M3 × 0.5	2.5 [2.2]	15.1	12.6 [12.9]	10.9	1.5	8	9.8	7.8	1.9	2.3	POC3-M3M(4)⑤
POC3-M5M (4)⑤		M5 × 0.8	3 [3.2]	15.6	12.6 [12.4]		2				2.8	3.2	POC3-M5M(4)⑤
POC3-M6M (4)⑤		M6 × 1	3.9	18.2	14.3	12.5	3				3.5	POC3-M6M(4)⑤	
POC4-M3M (4)⑤		M3 × 0.5	2.5 [2.2]	15.1	12.6 [12.9]	10.9	1.5				8	9.8	7.8
POC4-M5M (4)⑤	M5 × 0.8	3 [3.2]	15.6	12.6 [12.4]	2.5		5.1	3	POC4-M5M(4)⑤				
POC4-M6M (4)⑤	M6 × 1	3.9	16.6	12.7	3		7	3.3	POC4-M6M(4)⑤				
POC4-01M (4)⑤	R1/8	8	15.8	11.8	3		10	7.4	6.2	POC4-01M(4)⑤			
POC6-M5M (4)⑤	6	M5 × 0.8	3 [3.2]	17.5	14.5 [14.3]	11.7	2.5	9.8	11.8	9.8	5.2	4.4	POC6-M5M(4)⑤
POC6-M6M (4)⑤		M6 × 1	3.9	18	14.1		3				7.1	4.7	POC6-M6M(4)⑤
POC6-01M (4)⑤		R1/8	8	17.9	13.9		4				13	5.6	POC6-01M(4)⑤
POC1/8-M3M (4)⑤	1/8	M3 × 0.5	2.5 [2.2]	15.1	12.6 [12.9]	10.9	1.5	8	9.8	7.8	1.8	2.3	POC1/8-M3M(4)⑤
POC1/8-M5M (4)⑤		M5 × 0.8	3 [3.2]	15.6	12.6 [12.4]		2				3.3	3	POC1/8-M5M(4)⑤
POC1/8-M6M (4)⑤		M6 × 1	3.9	16.6	12.7		3				3.1	3.6	POC1/8-M6M(4)⑤
POC5/32-M3M (4)⑤	5/32	M3 × 0.5	2.5 [2.2]	15.1	12.6 [12.9]	10.9	1.5	8	9.8	7.8	1.8	2.2	POC5/32-M3M(4)⑤
POC5/32-M5M (4)⑤		M5 × 0.8	3 [3.2]	15.6	12.6 [12.4]		2.5				5.1	3	POC5/32-M5M(4)⑤
POC5/32-M6M (4)⑤		M6 × 1	3.9	16.6	12.7		3				7	3.3	POC5/32-M6M(4)⑤
POC5/32-01M (4)⑤		R1/8	8	15.8	11.8		3				10	7.4	6.2
POC1/4-M5M (4)⑤	1/4	M5 × 0.8	3 [3.2]	17.1	14.1 [13.9]	11.4	2.5	9.8	11.8	9.8	4.8	3.8	POC1/4-M5M(4)⑤
POC1/4-M6M (4)⑤		M6 × 1	4	17.7	13.7		3				7.3	4.1	POC1/4-M6M(4)⑤

- ※ 1. ④ in Model code / Replaced with "W" for Light-gray color
- ※ 2. ⑤ in Model code / Replaced with "C" for Clean-room package
- ※ 3. "L" is a reference value for height dimension after tightening taper thread.
- ※ 4. Dimensions in [] are for clean-room package products
- ※ 5. Visit PISCO website for CAD data of clean-room package products.



Cartridge

RoHS compliant

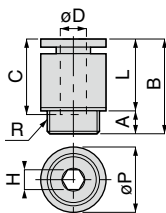

Release-ring dimension



Unit : mm

Model code	Tube O.D. ϕD	R	A	B	L	Tube end C	Hex. H	ϕP	X	Y	Effective area (mm^2)	Weight (g)	CAD file name
PCC3-M6M (4)⑤	3	M6 × 0.75	3	14	11	10.9	2	8	9.8	7.8	2.9	2.7	PCC3-M6M(4)⑤
PCC4-M6M (4)⑤	4	M6 × 0.75	3	14	11	10.9	2.5	8	9.8	7.8	5.1	2.6	PCC4-M6M(4)⑤
PCC4-M8M (4)⑤		M8 × 0.75	3.4	10.6	3		10				7.3	4.9	PCC4-M8M(4)⑤
PCC6-M8M (4)⑤	6	M8 × 0.75	3.4	14.8	11.4	11.7	4	10	11.8	9.8	12.8	3.6	PCC6-M8M(4)⑤
PCC1/8-M6M (4)⑤	1/8	M6 × 0.75	3	14	11	10.9	2	8	9.8	7.8	3	2.7	PCC1/8-M6M(4)⑤

- ※ 1. ④ in Model code / Replaced with "W" for Light-gray color
- ※ 2. ⑤ in Model code / Replaced with "C" for Clean-room package



Page for special specifications



3D CAD data is available at PISCO website.



CAD data is available at PISCO website.

PCF Mini Female Straight

RoHS compliant

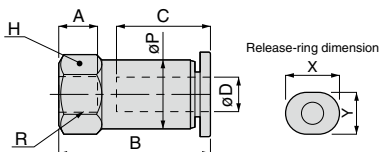

Unit : mm

Model code	Tube O.D. ϕD	R	A	B	ϕP	Tube end C	Hex. H	X	Y	Effective area (mm ²)	Weight (g)	CAD file name
PCF3-M3M ⁽⁴⁾⁽⁵⁾	3	M3×0.5	(4.35)	13.75	5.5	9.4	5.5	7	6	1.4	1.5	PCF3-M3M
PCF3-M5M ⁽⁴⁾⁽⁵⁾		M5×0.8	4.5	15.4	8		8			2.8	4.2	PCF3-M5M
PCF4-M3M ⁽⁴⁾⁽⁵⁾	4	M3×0.5	(4.5)	15.4	8	10.9	8	9.8	7.8	3.5	3.6	PCF4-M3M
PCF4-M5M ⁽⁴⁾⁽⁵⁾		M5×0.8	4.5	17.6						2.6	4.3	PCF4-M5M
PCF1/8-M3M ⁽⁴⁾⁽⁵⁾	1/8	M3×0.5	(4.5)	15.4	8	10.9	8	9.8	7.8	3.5	3.7	PCF1/8-M3M
PCF1/8-M5M ⁽⁴⁾⁽⁵⁾		M5×0.8	4.5	17.6						2.6	4.4	PCF1/8-M5M
PCF5/32-M3M ⁽⁴⁾⁽⁵⁾	5/32	M3×0.5	4.5	15.4	8	10.9	8	9.8	7.8	3.5	3.6	PCF5/32-M3M
PCF5/32-M5M ⁽⁴⁾⁽⁵⁾		M5×0.8		17.6						2.6	4.3	PCF5/32-M5M

* 1. ④ in Model code / Replaced with "W" for Light-gray color

* 2. ⑤ in Model code / Replaced with "C" for Clean-room package

PU Mini Union Straight

RoHS compliant

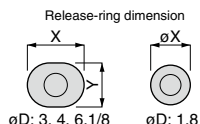
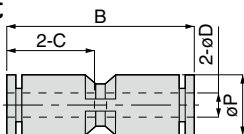

Unit : mm

Model code	Tube O.D. ϕD	B	ϕP	Tube end C	X (ϕX)	Y	Effective area (mm ²)	Weight (g)	CAD file name
PU180M ⁽⁴⁾⁽⁵⁾	1.8	18.5	6	8.4	4.8	—	0.6	1.1	PU180M
PU3M ⁽⁴⁾⁽⁵⁾	3	19.6	6	9.3	7	6	2.7	1.1	PU3M
PU4M ⁽⁴⁾⁽⁵⁾	4	22.7	8	11	9.8	7.8	5.4	2	PU4M
PU6M ⁽⁴⁾⁽⁵⁾	6	24.4	10.4	11.6	11.8	9.8	11	3.1	PU6M
PU1/8M ⁽⁴⁾⁽⁵⁾	1/8	22.7	8	11	9.8	7.8	2.6	2.1	PU1/8M
PU1/4M ⁽⁴⁾⁽⁵⁾	1/4	24.8	10.4	11.4	11.8	9.8	11.5	3.1	PU1/4M

* 1. ④ in Model code / Replaced with "W" for Light-gray color

* 2. ⑤ in Model code / Replaced with "C" for Clean-room package

PG Mini Unequal Union Straight

RoHS compliant

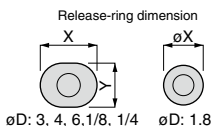
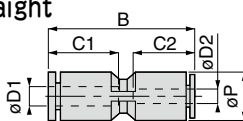

Unit : mm

Model code	Tube O.D. $\phi D1$	Tube O.D. $\phi D2$	B	ϕP	Tube end C1	Tube end C2	$\phi D1$ release-ring		$\phi D2$ release-ring		Effective area (mm ²)	Weight (g)	CAD file name									
							X	Y	X(ϕX)	Y												
PG3-180M ⁽⁴⁾⁽⁵⁾	3	1.8	19.1	6	9.3	8.4	7	6	4.8	—	0.6	1.1	PG3-180M									
PG4-180M ⁽⁴⁾⁽⁵⁾		1.8											22.4	8.4	—	0.6	1.8	PG4-180M				
PG4-3M ⁽⁴⁾⁽⁵⁾	4	3	22.7	8	11	11	9.8	7.8	9.8	7.8	2.4	2.1	PG4-3M									
PG4-1/8M ⁽⁴⁾⁽⁵⁾		1/8											—	—	—	—	—	—	—	—	—	PG4-1/8M
PG6-3M ⁽⁴⁾⁽⁵⁾	6	3	24	10.4	11.6	11	11.8	9.8	9.8	7.8	5.6	3	PG6-3M									
PG6-4M ⁽⁴⁾⁽⁵⁾		4											—	—	—	—	—	—	—	—	—	PG6-4M
PG6-1/8M ⁽⁴⁾⁽⁵⁾		1/8											—	—	—	—	—	—	—	—	—	—
PG1/4-1/8M ⁽⁴⁾⁽⁵⁾	1/4	1/8	24.2	10.4	11.4	11	11.8	9.8	9.8	7.8	4.7	3	PG1/4-1/8M									
PG1/4-5/32M ⁽⁴⁾⁽⁵⁾		5/32											—	—	—	—	—	—	—	—	—	—

* 1. ④ in Model code / Replaced with "W" for Light-gray color

* 2. ⑤ in Model code / Replaced with "C" for Clean-room package



Page for special specifications



3D CAD data is available at PISCO website.



CAD data is available at PISCO website.

PL Mini Elbow

RoHS compliant

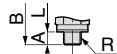
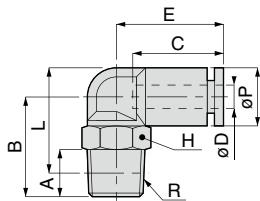

Metric thread type

Release-ring dimension

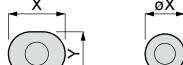

ϕD : 3, 4, 6, 1/8, 5/32, 1/4 ϕD : 1.8

Unit : mm

Model code	Tube O.D. ϕD	R	A	B	L	ϕP	Tube end C	E	Hex. H	X (ϕX)	Y	Effective area (mm ²)	Weight (g)	CAD file name	
PL180-M3M ④⑤	1.8	M3×0.5	2.5 [2.2]	12	12.5 [12.8]	6	8.4	10.3	5.5	4.8	-	0.5	1.4	PL180-M3M(※5)	
PL180-M5M ④⑤		M5×0.8	3 [3.2]	13.5	13.5 [13.3]				8					0.7	2.8
PL3-M3M ④⑤	3	M3×0.5	2.5 [2.2]	12	12.5 [12.8]	6	9.3	10.8	5.5	7	6	0.5	1.4	PL3-M3M(※5)	
PL3-M5M ④⑤		M5×0.8	3 [3.2]	13.5	13.5 [13.3]				8					2.8	PL3-M5M(※5)
PL3-M6M ④⑤		M6×1	3.9	14.5	13.6				8					3.1	PL3-M6M
PL3-01M ④⑤		R1/8	8	16	16				8					6.3	PL3-01M
PL4-M3M ④⑤	4	M3×0.5	2.5 [2.2]	14	15.5 [15.8]	8	11	15.1	8	9.8	7.8	1.3	3	PL4-M3M(※5)	
PL4-M5M ④⑤		M5×0.8	3 [3.2]	13.5	14.5 [14.3]									8	2.2
PL4-M6M ④⑤		M6×1	3.9	14.5	14.6				8			3.9	3.7	PL4-M6M	
PL4-01M ④⑤		R1/8	8	16	16				10			4.8	6.2	PL4-01M	
PL4-02M ④⑤		R1/4	11	21	19			14			4.9	13	PL4-02M		
PL6-M5M ④⑤	6	M5×0.8	3 [3.2]	14.5	16.8 [16.6]	10.5	11.6	16	8	11.8	9.8	3.5	4.1	PL6-M5M(※5)	
PL6-M6M ④⑤		M6×1	3.9	15.5	16.9									8	3.6
PL6-01M ④⑤		R1/8	8	17	18.3				10			8.5	6	PL6-01M	
PL6-02M ④⑤		R1/4	11	22.3	21.5				14			8.4	13	PL6-02M	
PL6-03M ④⑤		R3/8	12	23.3	22.2	17	8.6	21	PL6-03M						
PL1/8-M3M ④⑤	1/8	M3×0.5	2.5 [2.2]	14	15.5 [15.8]	8	11	15.1	8	9.8	7.8	0.9	3.1	PL1/8-M3M(※5)	
PL1/8-M5M ④⑤		M5×0.8	3 [3.2]	13.5	14.5 [14.3]									8	2.7
PL1/8-M6M ④⑤		M6×1	3.9	14.5	14.6				8			2.5	3.8	PL1/8-M6M	
PL1/8-01M ④⑤		R1/8	8	16	16				10			2	6.3	PL1/8-01M	
PL5/32-M3M ④⑥	5/32	M3×0.5	2.5 [2.2]	14	15.5 [15.8]	8	11	15.1	8	9.8	7.8	1.3	3	PL5/32-M3M(※5)	
PL5/32-M5M ④⑥		M5×0.8	3 [3.2]	13.5	14.5 [14.3]									8	2.8
PL5/32-M6M ④⑥		M6×1	3.9	14.5	14.6				8			3	3.7	PL5/32-M6M	
PL5/32-01M ④⑤		R1/8	8	16	16				10			3.2	6.2	PL5/32-01M	
PL5/32-02M ④⑥		R1/4	11	21	19				14			4.9	13	PL5/32-02M	
PL1/4-M5M ④⑤	1/4	M5×0.8	3 [3.2]	14.5	16.8 [16.6]	10.5	11.4	16.2	8	11.8	9.8	3	4.1	PL1/4-M5M(※5)	
PL1/4-M6M ④⑤		M6×1	3.9	15.5	16.9									8	3.7
PL1/4-01M ④⑤		R1/8	8	17	18.3				10			8.4	6.8	PL1/4-01M	

※ 1. ④ in Model code / Replaced with "W" for Light-gray color

※ 2. ⑤ in Model code / Replaced with "C" for Clean-room package

※ 3. "L" is a reference value for height dimension after tightening taper thread.

※ 4. Dimensions in [] are for clean-room package products

※ 5. Visit PISCO website for CAD data of clean-room package products.

PLL Mini Long Elbow

RoHS compliant

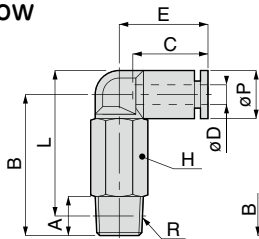

Metric thread type

Release-ring dimension

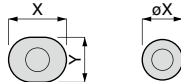

ϕD : 3, 4, 6, 1/8, 5/32, 1/4 ϕD : 1.8

Unit : mm

Model code	Tube O.D. ϕD	R	A	B	L	ϕP	Tube end C	E	Hex. H	X (ϕX)	Y	Effective area (mm ²)	Weight (g)	CAD file name		
PLL180-M3M④⑤	1.8	M3 × 0.5	2.5 [2.2]	19	19.5 [19.8]	6	8.4	10.3	5.5	4.8	-	0.8	2.7	PLL180-M3M(※5)		
PLL180-M5M④⑤		M5 × 0.8	3 [3.2]	25	25 [24.8]				8				7.6	PLL180-M5M(※5)		
PLL3-M3M④⑤	3	M3 × 0.5	2.5 [2.2]	19	19.5 [19.8]	6	9.3	10.8	5.5	7	6	0.6	2.8	PLL3-M3M(※5)		
PLL3-M5M④⑤		M5 × 0.8	3 [3.2]	25	25 [24.8]				8				7.7	PLL3-M5M(※5)		
PLL3-M6M④⑤		M6 × 1	3.9	26	25.1				2.1				PLL3-M6M			
PLL3-01M④⑤		R1/8	8	28.5	28.5				2.3				13	PLL3-01M		
PLL4-M3M④⑤		M3 × 0.5	2.5 [2.2]	23	24.5 [24.8]				8				11	15.1	8	9.8
PLL4-M5M④⑤	M5 × 0.8	3 [3.2]	25	26 [25.8]	3	8.3	PLL4-M5M(※5)									
PLL4-M6M④⑤	M6 × 1	3.9	26	26.1	3.7	8.4	PLL4-M6M									
PLL4-01M④⑤	R1/8	8	28.5	28.5	4.2	14	PLL4-01M									
PLL6-M5M④⑤	M5 × 0.8	3 [3.2]	26	28.3 [28.1]	10.5	11.6	16	8		11.8	9.8	3.3				
PLL6-M6M④⑤	M6 × 1	3.9	27	28.4					3.7				8.3	PLL6-M6M		
PLL6-01M④⑤	R1/8	8	29.5	30.8					7.6				14	PLL6-01M		
PLL1/8-M3M④⑤	1/8	M3 × 0.5	2.5 [2.2]	23	24.5 [24.8]	8	11	15.1	8	9.8	7.8	0.9	6.8	PLL1/8-M3M(※5)		
PLL1/8-M5M④⑤		M5 × 0.8	3 [3.2]	25	26 [25.8]									2.5	8.4	PLL1/8-M5M(※5)
PLL1/8-M6M④⑤		M6 × 1	3.9	26	26.1									2.1	PLL1/8-M6M	
PLL1/8-01M④⑤		R1/8	8	28.5	28.5									2.3	13	PLL1/8-01M
PLL5/32-M3M④⑤	5/32	M3 × 0.5	2.5 [2.2]	23	24.5 [24.8]	8	11	15.1	8	9.8	7.8	0.9	6.8	PLL5/32-M3M(※5)		
PLL5/32-M5M④⑤		M5 × 0.8	3 [3.2]	25	26 [25.8]									3	8.3	PLL5/32-M5M(※5)
PLL5/32-M6M④⑤		M6 × 1	3.9	26	26.1									3.7	8.4	PLL5/32-M6M
PLL5/32-01M④⑤		R1/8	8	28.5	28.5									4.2	14	PLL5/32-01M
PLL1/4-M5M④⑤	1/4	M5 × 0.8	3 [3.2]	26	28.3 [28.1]	10.5	11.4	16.2	8	11.8	9.8	3.5	8.8	PLL1/4-M5M(※5)		
PLL1/4-M6M④⑤		M6 × 1	3.9	27	28.4									3.6	8.8	PLL1/4-M6M
PLL1/4-01M④⑤		R1/8	8	29.5	30.8									8.4	14	PLL1/4-01M

- ※ 1. ④ in Model code / Replaced with "W" for Light-gray color
- ※ 2. ⑤ in Model code / Replaced with "C" for Clean-room package
- ※ 3. "L" is a reference value for height dimension after tightening taper thread.
- ※ 4. Dimensions in [] are for clean-room package products
- ※ 5. Visit PISCO website for CAD data of clean-room package products.

FITTING CONTROLLER VALVE TUBE MAKE-TO-ORDER PRODUCTS Mini Series Stainless Series Chemical Series PP Series EG Series Anti-siphon & Backflow Series Ball Control Minimal Series Stop Fitting Series Rotary Series Twist-Proof Fitting Block and Connector Coupling Color Cap

94



Fitting Series

Tube Fitting Mini Series

FITTING

PLH Mini 45° Elbow

RoHS compliant

OP. P.754

3D CAD

CAD

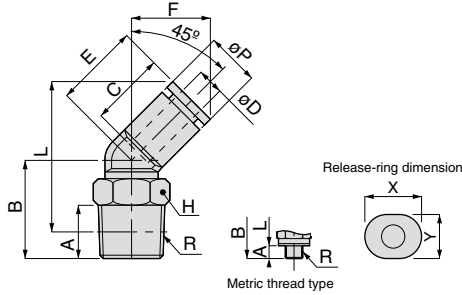

Unit : mm

Model code	Tube O.D. øD	R	A	B	L	øP	Tube end C	E	F	Hex. H	X	Y	Effective area (mm ²)	Weight (g)	CAD file name
PLH3-M3M(4)⑤	3	M3 × 0.5	2.5 (2.2)	12.8	22.3 (22.6)	8	11	12.2	12	8	9.8	7.8	0.8	2.9	PLH3-M3M(#5)
PLH3-M5M(4)⑤		M5 × 0.8	3 (3.2)	12.3	21.3 (21.1)								1.9	3.3	PLH3-M5M(#5)
PLH4-M3M(4)⑥		M3 × 0.5	2.5 (2.2)	12.8	22.3 (22.6)								1	2.8	PLH4-M3M(#5)
PLH4-M5M(4)⑥	4	M5 × 0.8	3 (3.2)	12.3	21.3 (21.1)	8	11	12.2	12	8	9.8	7.8	2.9	3.3	PLH4-M5M(#5)
PLH4-M6M(4)⑥		M6 × 1	3.9	13.3	21.4								4	3.6	PLH4-M6M
PLH4-01M(4)⑤		R1/8	8	14.8	22.8								5	6.1	PLH4-01M
PLH6-M5M(4)⑥	6	M5 × 0.8	3 (3.2)	14.1	23.9 (23.7)	10.5	11.6	12.3	12.8	8	11.8	9.8	3.6	3.9	PLH6-M5M(#5)
PLH6-M6M(4)⑥		M6 × 1	3.9	15.1	24								3.8	4.2	PLH6-M6M
PLH6-01M(4)⑤		R1/8	8	16.6	25.4								8.7	6.8	PLH6-01M
PLH6-02M(4)⑤		R1/4	11	21.6	28.4								8.7	18	PLH6-02M

- ※ 1. ④ in Model code / Replaced with "W" for Light-gray color
- ※ 2. ⑤ in Model code / Replaced with "C" for Clean-room package
- ※ 3. "L" is a reference value for height dimension after tightening taper thread.
- ※ 4. Dimensions in [] are for clean-room package products
- ※ 5. Visit PISCO website for CAD data of clean-room package products.

95

Standard Series

Mini Series

PV Mini Union Elbow

RoHS compliant

OP. P.754

3D CAD

CAD

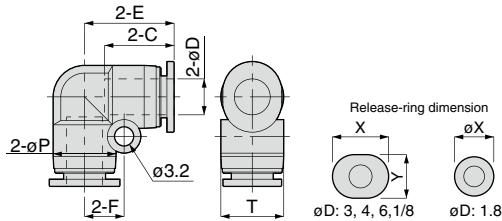

Unit : mm

Model code	Tube O.D. øD	øP	Tube end C	E	F	T	X (øX)	Y	Effective area (mm ²)	Weight (g)	CAD file name
PV180M(4)⑤	1.8	6	8.4	10.3	4.5	6	4.8	—	0.6	1.2	PV180M
PV3M(4)⑤	3	6	9.3	10.8	4.5	6	7	6	2.3	1.2	PV3M
PV4M(4)⑤	4	8	11	13.1	5.6	8	9.8	7.8	4.8	2.3	PV4M
PV6M(4)⑤	6	10.5	11.6	15	6.6	10.5	11.8	9.8	9	3.6	PV6M
PV1/8M(4)⑤	1/8	8	11	13.1	5.6	8	9.8	7.8	2.1	2.4	PV1'8M
PV1/4M(4)⑤	1/4	10.5	11.4	15.2	6.6	10.5	11.8	9.8	10.7	3.4	PV1'4M

- ※ 1. ④ in Model code / Replaced with "W" for Light-gray color
- ※ 2. ⑤ in Model code / Replaced with "C" for Clean-room package

OP. P.000

Page for special specifications

3D CAD

3D CAD data is available at PISCO website.

CAD

CAD data is available at PISCO website.

PLJ Mini Plug-in Elbow

RoHS compliant

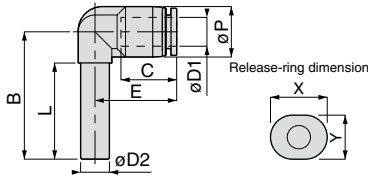

Unit : mm

Model code	Tube O.D. øD1	Tube dia. øD2	B	øP	Tube end C	E	L	X	Y	Effective area (mm ²)	Weight (g)	CAD file name
PLJ3M ④⑤	3	3	24	9	11	14.1	17	9.8	7.8	1.2	1.1	PLJ3M
PLJ4M ④⑤	4	4	25	9	11	14.1	18	9.8	7.8	3.2	1.8	PLJ4M
PLJ6M ④⑤	6	6	26.5	10.5	11.6	17	20	11.8	9.8	5.1	3.1	PLJ6M
PLJ1/8M ④⑤	1/8	1/8	24	9	11	14.1	17	9.8	7.8	1.2	1.7	PLJ1'8M
PLJ5/32M ④⑤	5/32	5/32	25	9	11	14.1	18	9.8	7.8	2.9	1.7	PLJ5'32M
PLJ3/16M ④⑤	3/16	3/16	27.5	10.5	11.7	17.1	20.5	11.8	9.8	4.8	2.5	PLJ3'16M
PLJ1/4M ④⑤	1/4	1/4	29	10.5	11.4	17.2	22.5	11.8	9.8	8.2	2.4	PLJ1'4M

※ 1. ④ in Model code / Replaced with "W" for Light-gray color

※ 2. ⑤ in Model code / Replaced with "C" for Clean-room package

PLGJ Mini Unequal Plug-in Elbow

RoHS compliant

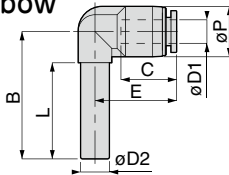

Unit : mm

Model code	Tube O.D. øD1	Tube dia. øD2	B	øP	Tube end C	E	L	X	Y	Effective area (mm ²)	Weight (g)	CAD file name								
PLGJ3-180M ④⑤	1.8	3	24	6	8.4	10.3	17	4.8	—	0.9	0.7	PLGJ3-180M								
PLGJ3-4M ④⑤	4			9	11	14.1		9.8	7.8		1.6	PLGJ3-4M								
PLGJ3-6M ④⑤	6		24.5	10.5	11.6	17		11.8	9.8		2.2	PLGJ3-6M								
PLGJ3-1/8M ④⑤	1/8	4	24	9	11	14.1	17	9.8	7.8	1.7	1.7	PLGJ3-1'8M								
PLGJ4-180M ④⑤	1.8			24	6	8.4		10.3	4.8		—	0.9	0.8	PLGJ4-180M						
PLGJ4-3M ④⑤	3		25	9	11	14.1		9.8	7.8		2.3	1.8	PLGJ4-3M							
PLGJ4-6M ④⑤	6	6	25.5	10.5	11.6	17	18	11.8	9.8	3.3	2.2	PLGJ4-6M								
PLGJ4-1/8M ④⑤	1/8			25	9	11		14.1	9.8		7.8	2.3	1.9	PLGJ4-1'8M						
PLGJ6-3M ④⑤	3		26	9	11	14.1		20	9.8		7.8	2.4	2.9	2.4	PLGJ6-3M					
PLGJ6-4M ④⑤	4	4.2					PLGJ6-4M													
PLGJ6-1/8M ④⑤	1/8	4.2					PLGJ6-1'8M													
PLGJ6-1/4M ④⑤	1/4	6	26.5	10.5	11.4	17.2	18	11.8	9.8	8.2	2.3	PLGJ6-1'4M								
PLGJ1'8-3M ④⑤	3										24	9	11	14.1	17	9.8	7.8	1.2	1.7	PLGJ1'8-3M
PLGJ1'8-5/32M ④⑤	5/32																		1.6	PLGJ1'8-5'32M
PLGJ1'8-1/4M ④⑤	1/4	24.5	10.5	11.4	17.2	11.8	9.8	2.1	PLGJ1'8-1'4M											
PLGJ5/32-1/8M ④⑤	1/8	5/32	25	9	11	14.1	18	9.8	7.8	2.3	1.7	PLGJ5'32-1'8M								
PLGJ5/32-1/4M ④⑤	1/4										25.5	10.5	11.4	17.2	11.8	9.8	3.3	2.1	PLGJ5'32-1'4M	
PLGJ3/16-1/8M ④⑤	1/8		3/16	27	9	11		14.1	20.5		9.8	7.8	2.3	1.8	PLGJ3'16-1'8M					
PLGJ3/16-5/32M ④⑤	5/32	2.9					1.7			PLGJ3'16-5'32M										
PLGJ3/16-1/4M ④⑤	1/4	27.5		10.5	11.4	17.2	11.8	9.8		4.8	2.2	PLGJ3'16-1'4M								
PLGJ1/4-1/8M ④⑤	1/8	1/4	28.5	9	11	14.1	22.5	9.8	7.8	2.4	6	PLGJ1'4-1'8M								
PLGJ1/4-5/32M ④⑤	5/32										2.9	1.9	PLGJ1'4-5'32M							
PLGJ1/4-6M ④⑤	6		29	10.5	11.6	17		11.8	9.8		8.2	2.5	PLGJ1'4-6M							

※ 1. ④ in Model code / Replaced with "W" for Light-gray color

※ 2. ⑤ in Model code / Replaced with "C" for Clean-room package



Page for special specifications



3D CAD data is available at PISCO website.



CAD data is available at PISCO website.

PLHJ Mini 45° Plug-in Elbow

RoHS compliant

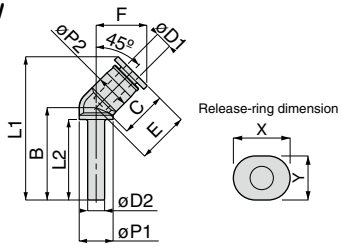

OP P.754 3D CAD CAD

Unit : mm

Model code	Tube O.D. øD1	Tube dia. øD2	B	øP1	øP2	Tube end C	L1	L2	E	F	X	Y	Effective area (mm ²)	Weight (g)	CAD file name
PLHJ4M ④⑤	4	4	21.8	8	8	11	33.8	18.5	12.2	12	9.8	7.8	3	1.3	PLHJ4M
PLHJ6M ④⑤	6	6	24.5	8	10.5	11.6	37.4	19.5	12.3	12.8	11.8	9.8	5.9	2.1	PLHJ6M

- ※ 1. ④ in Model code / Replaced with "W" for Light-gray color
- ※ 2. ⑤ in Model code / Replaced with "C" for Clean-room package

PGJ Mini Unequal Plug-in Straight

RoHS compliant

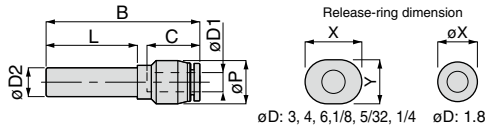

OP P.754 3D CAD CAD

Unit : mm

Model code	Tube O.D. øD1	Tube dia. øD2	B	L	øP	Tube end C	X (øX)	Y	Effective area (mm ²)	Weight (g)	CAD file name		
PGJ3-180M ④⑤	1.8	3	26.3	15	6	8.4	4.8	—	1.1	0.6	PGJ3-180M		
PGJ3-4M ④⑤	4		31	17	9	11	9.8	7.8	1.2	1.3	PGJ3-4M		
PGJ3-6M ④⑤	6		31.4		10.5	11.6	11.8	9.8		1.8	PGJ3-6M		
PGJ3-1/8M ④⑤	1/8	4	31	17	9	11	9.8	7.8		0.6	1.4	PGJ3-1/8M	
PGJ4-180M ④⑤	1.8		26.3		18	6	8.4	4.8	—		0.7	PGJ4-180M	
PGJ4-3M ④⑤	3		26.8	10.5		11.6	11.8	9.8	3.7		1.8	PGJ4-3M	
PGJ4-6M ④⑤	6	6	32.4	18	9	11	9.8	7.8	2.5	1.5	PGJ4-6M		
PGJ4-1/8M ④⑤	1/8		32		9	11	9.8	7.8		2.5	1.5	PGJ4-1/8M	
PGJ6-3M ④⑤	3		6	32	19	9	11	9.8		7.8	5.4	3.1	PGJ6-3M
PGJ6-4M ④⑤	4	5.4							2.4			0.7	PGJ6-4M
PGJ6-1/8M ④⑤	1/8	2.5							1.8			0.8	PGJ6-1/8M
PGJ6-1/4M ④⑤	1/4	1/8	32.6	17	10.5	11.4	11.8	9.8	9.2	1.9	PGJ6-1/4M		
PGJ1/8-5/32M ④⑤	5/32		31		9	11	9.8	7.8	1.2	1.3	PGJ1/8-5/32M		
PGJ1/8-1/4M ④⑤	1/4		31.6	10.5	11.4	11.8	9.8	1.7		1.7	PGJ1/8-1/4M		
PGJ5/32-1/8M ④⑤	1/8	5/32	32	18	9	11	9.8	7.8	2.5	1.5	PGJ5/32-1/8M		
PGJ5/32-1/4M ④⑤	1/4		32.6		10.5	11.4	11.8	9.8		3.7	1.7	PGJ5/32-1/4M	
PGJ3/16-1/8M ④⑤	1/8		3/16	34	21	9	11	9.8		7.8	3.4	1.6	PGJ3/16-1/8M
PGJ3/16-5/32M ④⑤	5/32	20.5		3.4	1.5				PGJ3/16-5/32M				
PGJ3/16-1/4M ④⑤	1/4	34.6		20.5	10.5	11.4	11.8	9.8	5	1.9		PGJ3/16-1/4M	
PGJ1/4-1/8M ④⑤	1/8	1/4	35.5	22.5	9	11	9.8	7.8	2.5	1.8	PGJ1/4-1/8M		
PGJ1/4-5/32M ④⑤	5/32									3.4	1.7	1.7	PGJ1/4-5/32M
PGJ1/4-6M ④⑤	6		35.9	10.5	11.6	11.8	9.8	10.9		2.1	PGJ1/4-6M		

- ※ 1. ④ in Model code / Replaced with "W" for Light-gray color
- ※ 2. ⑤ in Model code / Replaced with "C" for Clean-room package



Branch Tee

RoHS compliant

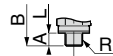
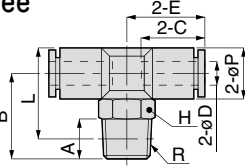

Metric thread type



Release-ring dimension

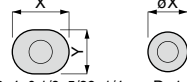

øD: 3, 4, 6, 1/8, 5/32, 1/4 øD: 1.8

Unit : mm

Model code	Tube O.D. øD	R	A	B	L	øP	Tube end C	E	Hex. H	X (øX)	Y	Effective area (mm ²)	Weight (g)	CAD file name	
PB180-M3M (4)⑤	1.8	M3 × 0.5	2.5 [2.2]	12	12.5 [12.8]	6	8.4	10.25	5.5	4.8	-	0.6	1.9	PB180-M3M(ø5)	
PB180-M5M (4)⑤		M5 × 0.8	3 [3.2]	13.5	13.5 [13.3]				8			0.7	3.2	PB180-M5M(ø5)	
PB3-M3M (4)⑤	3	M3 × 0.5	2.5 [2.2]	12	12.5 [12.8]	6	9.3	10.8	5.5	7	6	0.7	1.9	PB3-M3M(ø5)	
PB3-M5M (4)⑤		M5 × 0.8	3 [3.2]	13.5	13.5 [13.3]				8			2	3.3	PB3-M5M(ø5)	
PB3-M6M (4)⑤		M6 × 1	3.9	14.5	13.6							1.9	3.6	PB3-M6M	
PB3-01M (4)⑤		R1/8	8	17	17				8			11	12.5	10	9.8
PB4-M3M (4)⑤	4	M3 × 0.5	2.5 [2.2]	15	16.5 [16.8]	8	11	12.5	8	9.8	7.8	1.4	3.9	PB4-M3M(ø5)	
PB4-M5M (4)⑤		M5 × 0.8	3 [3.2]	14.5	15.5 [15.3]								3.7	4.3	PB4-M5M(ø5)
PB4-M6M (4)⑤		M6 × 1	3.9	15.5	15.6							2.8	4.6	PB4-M6M	
PB4-01M (4)⑤		R1/8	8	17	17							4.6	7.2	PB4-01M	
PB4-02M (4)⑤		R1/4	11	22	20							4.4	13	PB4-02M	
PB6-M5M (4)⑤	6	M5 × 0.8	3 [3.2]	15.5	17.8 [17.6]	10.5	11.6	13.9	8	11.8	9.8	3.5	5.6	PB6-M5M(ø5)	
PB6-M6M (4)⑤		M6 × 1	3.9	16.5	17.9								3.6	5.9	PB6-M6M
PB6-01M (4)⑤		R1/8	8	18	19.3							8.5	8.4	PB6-01M	
PB6-02M (4)⑤		R1/4	11	23.3	22.5				8.1			15	PB6-02M		
PB6-03M (4)⑤		R3/8	12	24.3	23.2				8.5			22	PB6-03M		
PB18-M3M (4)⑤	1/8	M3 × 0.5	2.5 [2.2]	15	16.5 [16.8]	8	11	12.5	8	9.8	7.8	0.9	4.1	PB18-M3M(ø5)	
PB18-M5M (4)⑤		M5 × 0.8	3 [3.2]	14.5	15.5 [15.3]								2.1	4.4	PB18-M5M(ø5)
PB18-M6M (4)⑤		M6 × 1	3.9	15.5	15.6								2.2	4.7	PB18-M6M
PB18-01M (4)⑤		R1/8	8	17	17							2.3	7.3	PB18-01M	
PB5/32-M3M (4)⑤	5/32	M3 × 0.5	2.5 [2.2]	15	16.5 [16.8]	8	11	12.5	8	9.8	7.8	1.4	3.9	PB5/32-M3M(ø5)	
PB5/32-M5M (4)⑤		M5 × 0.8	3 [3.2]	14.5	15.5 [15.3]								2.8	4.3	PB5/32-M5M(ø5)
PB5/32-M6M (4)⑤		M6 × 1	3.9	15.5	15.6							2.9	4.6	PB5/32-M6M	
PB5/32-01M (4)⑤		R1/8	8	17	17							3.3	7.2	PB5/32-01M	
PB5/32-02M (4)⑤		R1/4	11	22	20							4.4	13	PB5/32-02M	
PB14-M5M (4)⑤	1/4	M5 × 0.8	3 [3.2]	15.5	17.8 [17.6]	10.5	11.4	14.1	8	11.8	9.8	3.3	5.3	PB14-M5M(ø5)	
PB14-M6M (4)⑤		M6 × 1	3.9	16.5	17.9								3.6	5.6	PB14-M6M
PB14-01M (4)⑤		R1/8	8	18	19.3							8	8.1	PB14-01M	

- ※ 1. ④ in Model code / Replaced with "W" for Light-gray color
- ※ 2. ⑤ in Model code / Replaced with "C" for Clean-room package
- ※ 3. "L" is a reference value for height dimension after tightening taper thread.
- ※ 4. Dimensions in [] are for clean-room package products
- ※ 5. Visit PISCO website for CAD data of clean-room package products.

PD Mini Run Tee
RoHS compliant

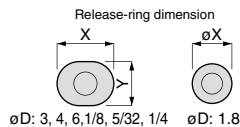
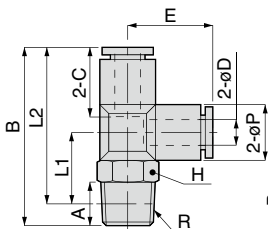

Unit : mm

Model code	Tube O.D. φD	R	A	B	L1	L2	φP	Tube end C	E	Hex. H	X (φX)	Y	Effective area (mm ²)	Weight (g)	CAD file name
PD180-M3M ⁽⁴⁾⁽⁵⁾	1.8	M3 × 0.5	2.5 [2.2]	22.3	9.5 [9.8]	19.8 [20.1]	6	8.4	10.3	5.5	4.8	-	0.6	1.9	PD180-M3M(φ5)
PD180-M5M ⁽⁴⁾⁽⁵⁾		M5 × 0.8	3 [3.2]	23.8	10.5 [10.3]	20.8 [20.6]				8			0.8	3.2	PD180-M5M(φ5)
PD3-M3M ⁽⁴⁾⁽⁵⁾	3	M3 × 0.5	2.5 [2.2]	22.8	9.5 [9.8]	20.3 [20.6]	6	9.3	10.8	5.5	7	6	0.7	1.9	PD3-M3M(φ5)
PD3-M5M ⁽⁴⁾⁽⁵⁾		M5 × 0.8	3 [3.2]	24.3	10.5 [10.3]	21.3 [21.1]				8			2.2	3.2	PD3-M5M(φ5)
PD3-M6M ⁽⁴⁾⁽⁵⁾		M6 × 1	3.9	25.3	10.6	21.4							2	3.6	PD3-M6M
PD3-01M ^{(4)(5)*}		R1/8	8	30.1	13	26.1				8			11	13.1	10
PD4-M3M ⁽⁴⁾⁽⁵⁾	4	M3 × 0.5	2.5 [2.2]	28.1	12.5 [12.8]	25.6 [25.9]	8	11	13.1	8	9.8	7.8	0.9	4	PD4-M3M(φ5)
PD4-M5M ⁽⁴⁾⁽⁵⁾		M5 × 0.8	3 [3.2]	27.6	11.5 [11.3]	24.6 [24.4]								2.1	4.4
PD4-M6M ⁽⁴⁾⁽⁵⁾		M6 × 1	3.9	28.6	11.6	24.7							2.2	4.7	PD4-M6M
PD4-01M ⁽⁴⁾⁽⁵⁾		R1/8	8	30.1	13	26.1				10			4.6	7.3	PD4-01M
PD4-02M ⁽⁴⁾⁽⁵⁾		R1/4	11	35.1	16	29	14	3.3	14	PD4-02M					
PD6-M5M ⁽⁴⁾⁽⁵⁾	6	M5 × 0.8	3 [3.2]	30.5	12.5 [12.3]	27.5 [27.3]	10.5	11.6	15	8	11.8	9.8	2.2	5.6	PD6-M5M(φ5)
PD6-M6M ⁽⁴⁾⁽⁵⁾		M6 × 1	3.9	31.5	12.6	27.6								3.3	5.9
PD6-01M ⁽⁴⁾⁽⁵⁾		R1/8	8	33	14	29				10			8.5	8.4	PD6-01M
PD6-02M ⁽⁴⁾⁽⁵⁾		R1/4	11	38	17	31.9				14			6.6	15	PD6-02M
PD6-03M ⁽⁴⁾⁽⁵⁾		R3/8	12	39	17.7	32.6				17			8.9	23	PD6-03M
PD1'8-M3M ⁽⁴⁾⁽⁵⁾	1/8	M3 × 0.5	2.5 [2.2]	28.1	12.5 [12.8]	25.6 [25.9]	8	11	13.1	8	9.8	7.8	0.9	4.1	PD1'8-M3M(φ5)
PD1'8-M5M ⁽⁴⁾⁽⁵⁾		M5 × 0.8	3 [3.2]	27.6	11.5 [11.3]	24.6 [24.4]								2.4	4.5
PD1'8-M6M ⁽⁴⁾⁽⁵⁾		M6 × 1	3.9	28.6	11.6	24.7				10			2	4.8	PD1'8-M6M
PD1'8-01M ⁽⁴⁾⁽⁵⁾		R1/8	8	30.1	13	26.1		2.5	7.4	PD1'8-01M					
PD5'32-M3M ⁽⁴⁾⁽⁵⁾	5/32	M3 × 0.5	2.5 [2.2]	28.1	12.5 [12.8]	25.6 [25.9]	8	11	13.1	8	9.8	7.8	0.9	4	PD5'32-M3M(φ5)
PD5'32-M5M ⁽⁴⁾⁽⁵⁾		M5 × 0.8	3 [3.2]	27.6	11.5 [11.3]	24.6 [24.4]								4.4	
PD5'32-M6M ⁽⁴⁾⁽⁵⁾		M6 × 1	3.9	28.6	11.6	24.7							4.7		PD5'32-M6M
PD5'32-01M ⁽⁴⁾⁽⁵⁾		R1/8	8	30.1	13	26.1				10			7.3		PD5'32-01M
PD5'32-02M ⁽⁴⁾⁽⁵⁾		R1/4	11	35.1	16	29				14			3.3	14	PD5'32-02M
PD1'4-M5M ⁽⁴⁾⁽⁵⁾	1/4	M5 × 0.8	3 [3.2]	30.7	12.5 [12.3]	27.7 [27.5]	10.5	11.4	15.2	8	11.8	9.8	3.6	5.4	PD1'4-M5M(φ5)
PD1'4-M6M ⁽⁴⁾⁽⁵⁾		M6 × 1	3.9	31.7	12.6	27.8								3.7	5.6
PD1'4-01M ⁽⁴⁾⁽⁵⁾		R1/8	8	33.2	14	29.2				10			8.5	8.2	PD1'4-01M

- * 1. ④ in Model code / Replaced with "W" for Light-gray color
- * 2. ⑤ in Model code / Replaced with "C" for Clean-room package
- * 3. "L1" and "L2" are reference values for height dimensions after tightening taper thread.
- * 4. Dimensions in [] are for clean-room package products
- * 5. Visit PISCO website for CAD data of clean-room package products.



FITTING
 CONTROLLER
 VALVE
 TUBE
 MAKE-TO-ORDER PRODUCTS
 Mini Series
 Stainless Series
 Chemical Series
 PP Series
 EG Series
 Anti-suction & Back Series
 The Temperature Control
 Minimal Series
 Stop Fitting Series
 Rotary Series
 Twist-Proof Fitting
 Block and Connector
 Coupling
 Color Cap

100

PE Mini Union Tee

RoHS compliant

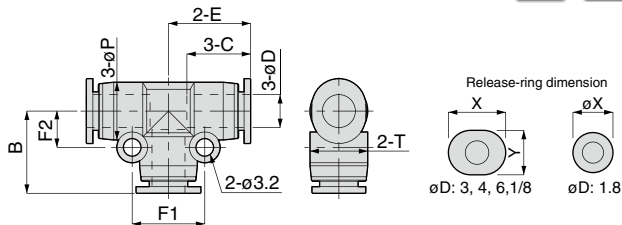

Unit : mm

Model code	Tube O.D. øD	B	øP	Tube end C	E	F1	F2	T	X (øX)	Y	Effective area (mm ²)	Weight (g)	CAD file name
PE180M④⑤	1.8	10.3	6	8.4	10.25	9	4.5	6	4.8	—	0.6	1.7	PE180M
PE3M④⑤	3	10.8	6	9.3	10.8	9	4.5	6	7	6	1.9	1.7	PE3M
PE4M④⑤	4	13.1	8	11	13.05	11.2	5.6	8	9.8	7.8	4.6	3.3	PE4M
PE6M④⑤	6	15	10.5	11.6	14.95	13.2	6.6	10.5	11.8	9.8	8.9	5.3	PE6M
PE1/8M④⑤	1/8	13.1	8	11	13.05	11.2	5.6	8	9.8	7.8	2.1	3.4	PE1/8M
PE1/4M④⑤	1/4	15.2	10.5	11.4	15.15	13.2	6.6	10.5	11.8	9.8	11.4	5	PE1/4M

※ 1. ④ in Model code / Replaced with "W" for Light-gray color

※ 2. ⑤ in Model code / Replaced with "C" for Clean-room package

PEG Mini Unequal Union Tee

RoHS compliant

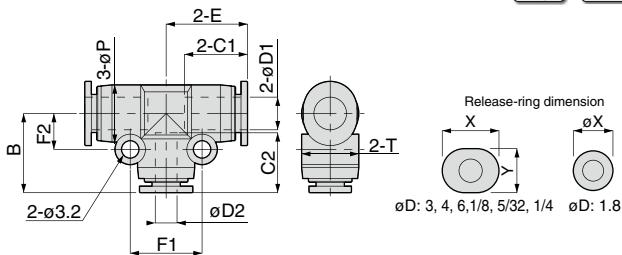

Unit : mm

Model code	Tube O.D. øD1	Tube O.D. øD2	B	øP	Tube end C1	Tube end C2	E	F1	F2	T	D1 release-ring		D2 release-ring		Effective area (mm ²)	Weight (g)	CAD file name					
											X	Y	X(øX)	Y								
PEG3-180M④⑤	3	1.8	10.3	6	9.3	8.4	10.8	9	4.5	6	7	6	4.8	—	1	1.7	PEG3-180M					
PEG3-4M④⑤		4	13.1	8	11	11	13.05	11.2	5.6	8	9.8	7.8	9.8	7.8	1.7	3.4	PEG3-4M					
PEG4-3M④⑤	4	3	13.1	8	11	13.05	11.2	5.6	8	9.8	7.8	9.8	7.8	2.4	3.3	PEG4-3M						
PEG4-6M④⑤		6	15	10.5	11	11.6	14.55	13.2	6.6								10.5	11.8	9.8	3.7	4.9	PEG4-6M
PEG4-1/8M④⑤		1/8	13.1	8	11	13.05	11.2	5.6	8								9.8	7.8	2.3	3.3	PEG4-1/8M	
PEG6-4M④⑤	6	4	14.6	10.5	11.6	11	14.95	13.2	6.6	10.5	11.8	9.8	9.8	7.8	5.3	5.1	PEG6-4M					
PEG1/8-5/32M④⑤	1/8	5/32	13.1	8	11	11	13.05	11.2	5.6	8	9.8	7.8	9.8	7.8	1.7	3.4	PEG1/8-5/32M					
PEG5/32-1/4M④⑤	5/32	1/4	15.2	10.5	11	11.4	14.55	13.2	6.6	10.5	9.8	7.8	11.8	9.8	3.7	4.8	PEG5/32-1/4M					
PEG1/4-5/32M④⑤	1/4	5/32	14.6	10.5	11.4	11	15.15	13.2	6.6	10.5	11.8	9.8	9.8	7.8	3.6	5.9	PEG1/4-5/32M					

※ 1. ④ in Model code / Replaced with "W" for Light-gray color

※ 2. ⑤ in Model code / Replaced with "C" for Clean-room package

PY Mini Union Y

RoHS compliant

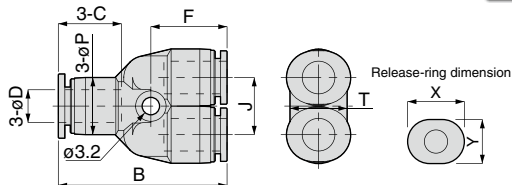

Unit : mm

Model code	Tube O.D. øD	B	øP	Tube end C	J	F	T	X	Y	Effective area (mm ²)	Weight (g)	CAD file name
PY3M④⑤	3	28	8	9.3	8	12.8	8	7	6	2	2.7	PY3M
PY4M④⑤	4	27.6	8	11	8	12.6	8	9.8	7.8	2.3	3.4	PY4M
PY6M④⑤	6	31	10.5	11.6	10.5	14	10.5	11.8	9.8	6.8	5.5	PY6M
PY1/8M④⑤*	1/8	27.6	8	11	8	12.6	8	9.8	7.8	1.1	3.6	PY1/8M
PY1/4M④⑤*	1/4	31.4	10.5	11.4	10.5	14.2	10.5	11.8	9.8	9.6	5.3	PY1/4M

※ 1. ④ in Model code / Replaced with "W" for Light-gray color

※ 2. ⑤ in Model code / Replaced with "C" for Clean-room package

PW Mini Unequal Union Y

RoHS compliant

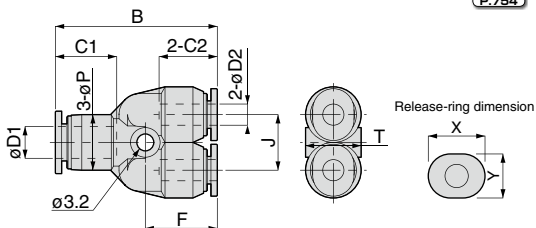

Unit : mm

Model code	Tube O.D. øD1	Tube O.D. øD2	B	øP	Tube end C1	Tube end C2	J	F	T	D1側開放リング		D2側開放リング		Effective area (mm ²)	Weight (g)	CAD file name		
										X	Y	X	Y					
PW4-3M④⑤	4	3	27.8	8	11	9.3	8	12.8	8	9.8	7.8	7	6	2.1	3	PW4-3M		
PW4-1/8M④⑤*		1/8										11	12.6				9.8	7.8
PW6-3M④⑤	6	3	30.6	10.5	11.6	11	10.5	13.6	10.5	11.8	9.8	9.8	7.8	2.5	5.3	PW6-3M		
PW6-4M④⑤		1/8															4.2	4.2
PW6-1/8M④⑤*														1/8	2.4	2.4	2.4	5.4
PW1/8-3M④⑤*	1/8	3	27.6	8	11	11	8	12.6	8	9.8	7.8	9.8	7.8	1.7	3	PW1/8-3M		
PW1/4-1/8M④⑤*	1/4	1/8															30.8	10.5
PW1/4-5/32M④⑤*		5/32	3.6	6.9	3.6	6.9	PW1/4-5/32M											

※ 1. ④ in Model code / Replaced with "W" for Light-gray color

※ 2. ⑤ in Model code / Replaced with "C" for Clean-room package

FITTING
CONTROLLER
VALVE
TUBE
MAKE-TO-ORDER
PRODUCTS
102
Mini Series
Stainless Series
Chemical Series
PP Series
EG Series
Anti-siphon & Backflow Series
Self-temperature Control
Minimal Series
Stop Fitting Series
Rotary Series
Twist-Proof Fitting
Block and Connector
Coupling
Color Cap

PYJ Mini Plug-in Y

RoHS compliant

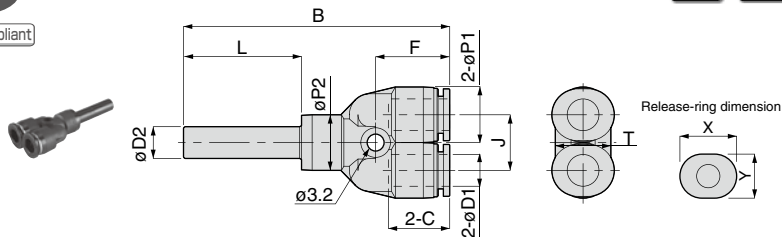

Unit : mm

Model code	Tube O.D. φD1	Tube dia. φD2	B	φP1	φP2	Tube end C	L	F	J	T	X	Y	Effective area (mm ²)	Weight (g)	CAD file name
PYJ3M④⑤	3	3	42.8	8	8	9.3	17.4	12.8	8	8	7	6	0.8	2.6	PYJ3M
PYJ4M④⑤	4	4	45	8	8	11	19	12.6	8	8	9.8	7.8	2.2	3.2	PYJ4M
PYJ6M④⑤	6	6	50.3	10.5	10.5	11.6	22	14	10.5	10.5	11.8	9.8	5.6	5.4	PYJ6M
PYJ1/8M④⑤	1/8	1/8	42.6	8	8	11	16.6	12.6	8	8	9.8	7.8	1.1	3.2	PYJ1/8M

※ 1. ④ in Model code / Replaced with "W" for Light-gray color

※ 2. ⑤ in Model code / Replaced with "C" for Clean-room package

PWJ Mini Unequal Plug-in Y

RoHS compliant

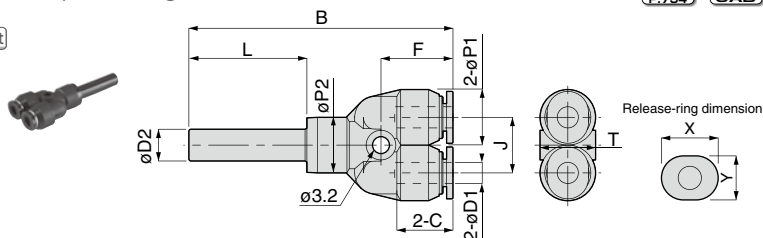

Unit : mm

Model code	Tube O.D. φD1	Tube dia. φD2	B	φP1	φP2	Tube end C	L	F	J	T	X	Y	Effective area (mm ²)	Weight (g)	CAD file name
PWJ4-3M④⑤	3	4	44.8	8	8	9.3	19	12.8	8	8	7	6	2.6	2.8	PWJ4-3M
PWJ4-1/8M④⑤	1/8		44.6			11		12.6					1.7	3.3	PWJ4-1/8M
PWJ6-3M④⑤	3	6	49.9	10.5	10.5	11	22	13.6	10.5	10.5	9.8	7.8	4.5	5.2	PWJ6-3M
PWJ6-4M④⑤	4												5.3	5.1	PWJ6-4M
PWJ6-1/8M④⑤	1/8												5.3	5.2	PWJ6-1/8M
PWJ5/32-1/8M④⑤	1/8												5/32	44.6	8

※ 1. ④ in Model code / Replaced with "W" for Light-gray color

※ 2. ⑤ in Model code / Replaced with "C" for Clean-room package

PZA Mini Cross A

RoHS compliant

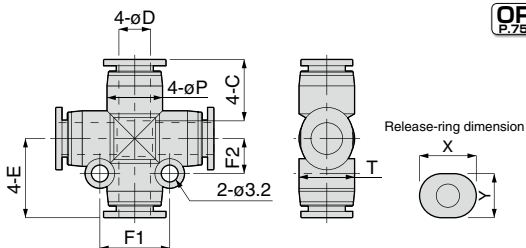

Unit : mm

Model code	Tube O.D. øD	E	øP	Tube end C	F1	F2	T	X	Y	Effective area (mm ²)	Weight (g)	CAD file name
PZA3M④⑤	3	13.05	8	11	11.2	5.6	8	9.8	7.8	2.2	4.6	PZA3M
PZA4M④⑤	4	13.05	8	11	11.2	5.6	8	9.8	7.8	4.8	4.3	PZA4M
PZA6M④⑤	6	14.95	10.5	11.6	13.2	6.6	10.5	11.8	9.8	8.8	6.7	PZA6M
PZA1'8M④⑤	1/8	13.05	8	11	11.2	5.6	8	9.8	7.8	4.8	4.5	PZA1'8M

※ 1. ④ in Model code / Replaced with "W" for Light-gray color

※ 2. ⑤ in Model code / Replaced with "C" for Clean-room package

PZB Mini Cross B

RoHS compliant

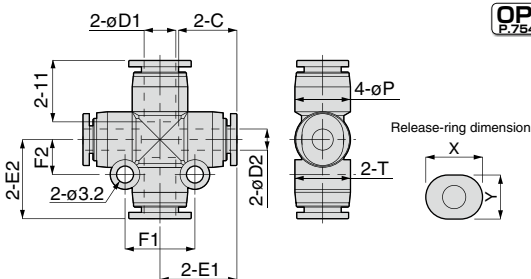

Unit : mm

Model code	Tube O.D. øD1	Tube O.D. øD2	E1	E2	øP	Tube end C	F1	F2	T	D1 release-ring		D2 release-ring		Effective area (mm ²)	Weight (g)	CAD file name
										X	Y	X	Y			
PZB4-3M④⑤	4	3	13.05	13.05	8	11	11.2	5.6	8	9.8	7.8	9.8	7.8	2.2	4.4	PZB4-3M
PZB4-1'8M④⑤		1/8														PZB4-1'8M
PZB6-4M④⑤	6	4	14.55	14.95	10.5	11.6	13.2	6.6	10.5	11.8	9.8	9.8	7.8	5.3	6.5	PZB6-4M
PZB6-1'8M④⑤		1/8														PZB6-1'8M
PZB1'8-3M④⑤	1/8	3	13.05	13.05	8	11	11.2	5.6	8	9.8	7.8	9.8	7.8	2.2	4.5	PZB1'8-3M
PZB5'32-1'8M④⑤	5/32	1/8	13.05	13.05	8	11	11.2	5.6	8	9.8	7.8	9.8	7.8	2.2	4.4	PZB5'32-1'8M

※ 1. ④ in Model code / Replaced with "W" for Light-gray color

※ 2. ⑤ in Model code / Replaced with "C" for Clean-room package

104

Mini Series

Stainless Series

Chemical Series

PP Series

EG Series

Anti-sucker & Pass Series

Self-Compensating Control

Minimal Series

Stop Fitting Series

Rotary Series

Twist-Proof Fitting

Block and Connector

Coupling

Color Cap



Page for special specifications



3D CAD data is available at PISCO website.



CAD data is available at PISCO website.

PZC Mini Cross C

RoHS compliant

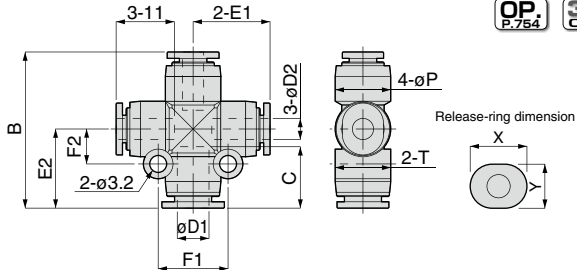

OP.
P.754

3D
CAD

CAD

Unit : mm

Model code	Tube O.D. øD1	Tube O.D. øD2	B	E1	E2	øP	Tube end C	F1	F2	T	D1 release-ring		D2 release-ring		Effective area (mm ²)	Weight (g)	CAD file name
											X	Y	X	Y			
PZC4-3M ⁽⁴⁾⁽⁵⁾	4	3	26.1	13.05	13.05	8	11	11.2	5.6	8	9.8	7.8	9.8	7.8	2.2	4.4	PZC4-3M
PZC4-1/8M ⁽⁴⁾⁽⁵⁾		1/8															2.4
PZC6-4M ⁽⁴⁾⁽⁵⁾	6	4	29.5	14.55	14.95	10.5	11.6	13.2	6.6	10.5	11.8	9.8	9.8	7.8	4.9	6.3	PZC6-4M
PZC6-1/8M ⁽⁴⁾⁽⁵⁾		1/8															2.4
PZC1/8-3M ⁽⁴⁾⁽⁵⁾	1/8	3	26.1	13.05	13.05	8	11	11.2	5.6	8	9.8	7.8	9.8	7.8	1.9	4.5	PZC1/8-3M
PZC5/32-1/8M ⁽⁴⁾⁽⁵⁾	5/32	1/8	26.1	13.05	13.05	8	11	11.2	5.6	8	9.8	7.8	9.8	7.8	2.2	4.4	PZC5/32-1/8M

※ 1. ④ in Model code / Replaced with "W" for Light-gray color

※ 2. ⑤ in Model code / Replaced with "C" for Clean-room package

PM Mini Bulkhead Union

RoHS compliant

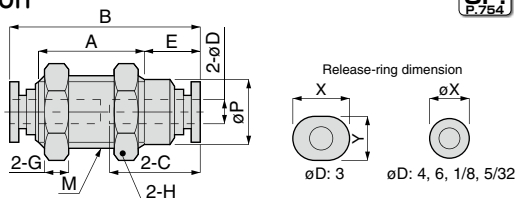

OP.
P.754

3D
CAD

CAD

Unit : mm

Model code	Tube O.D. øD	M	B	E	A	øP	Tube end C	Hex. H	G	X (øX)	Y	Effective area (mm ²)	Weight (g)	CAD file name
PM3M ⁽⁴⁾⁽⁵⁾	3	M8×0.75	19.5	4.8	12.4	7	9.4	10	2	7	6	2.4	3.1	PM3M
PM4M ⁽⁴⁾⁽⁵⁾	4	M10×1	23.2	5.8	14.1	8.9	10.9	12	3	7.8	—	3.7	6	PM4M
PM6M ⁽⁴⁾⁽⁵⁾	6	M12×1	25	6.6	14.8	10.8	11.7	14	4	9.8	—	10.5	9	PM6M
PM1/8M ⁽⁴⁾⁽⁵⁾	1/8	M10×1	23.2	5.8	14.1	8.9	10.9	12	3	7.8	—	2.1	6.1	PM1/8M
PM5/32M ⁽⁴⁾⁽⁵⁾	5/32	M10×1	23.2	5.8	14.1	8.9	10.9	12	3	7.8	—	3.7	6	PM5/32M
PM1/4M ⁽⁴⁾⁽⁵⁾	1/4	M12×1	24.6	6.4	14.8	10.8	11.4	14	4	9.8	—	11.2	8.8	PM1/4M

※ 1. ④ in Model code / Replaced with "W" for Light-gray color

※ 2. ⑤ in Model code / Replaced with "C" for Clean-room package

PF Mini Extension Screw Adaptor



RoHS compliant

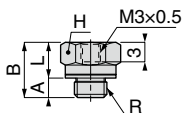

Metric thread type

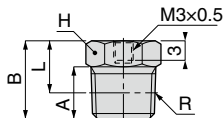

Taper pipe thread type

Unit : mm

Model code	R	A	B	L	Hex. H	Effective area (mm ²)	Weight (g)	CAD file name
PFM5-M3M ^⑤	M5 × 0.8	3 [3.2]	8.5	5.5 [5.3]	8	4.5	2.4	PFM5-M3M(※4)
PF01-M3M ^⑤	R1/8	8	12	8	10	4.5	6.8	PF01-M3M

- ※ 1. ⑤ in Model code / Replaced with "C" for Clean-room package
- ※ 2. "L" is a reference value for height dimension after tightening taper thread.
- ※ 3. Dimensions in [] are for clean-room package products
- ※ 4. Visit PISCO website for CAD data of clean-room package products.

PJ Mini Union Stem



RoHS compliant

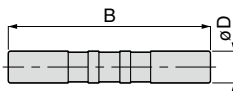

Unit : mm

Model code	Tube dia. øD	B	Effective area (mm ²)	Weight (g)	CAD file name
PIJ3M ^{④⑤}	3	27.1	2.5	0.2	PIJ3M
PIJ1'8M ^{④⑤}	1/8	27.1	2.5	0.2	PIJ1'8M

- ※ 1. ④ in Model code / Replaced with "W" for Light-gray color
- ※ 2. ⑤ in Model code / Replaced with "C" for Clean-room package

106

Mini Series

Stainless Series

Chemical Series

PP Series

EG Series

Anti-siphon & Press Series

Oil Temperature Control

Minimal Series

Stop Fitting Series

Rotary Series

Twist-Proof Fitting

Block and Connector

Coupling

Color Cap



Page for special specifications



3D CAD data is available at PISCO website.



CAD data is available at PISCO website.

Fitting Series

Tube Fitting Mini Series

FITTING

PP Mini Plug

RoHS compliant

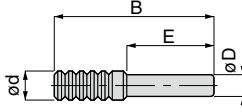

OP P.754

3D CAD

CAD

Unit : mm

Model code	ϕD	ϕd	B	E	Weight (g)	CAD file name
PP180M ④⑤	1.8	3	20	9.8	0.1	PP180M
PP3M ④⑤	3	4	22	11.8	0.2	PP3M

※ 1. ④ in Model code / Replaced with "W" for Light-gray color

※ 2. ⑤ in Model code / Replaced with "C" for Clean-room package

107

Standard Series

Mini Series

PPF Mini Cap

RoHS compliant

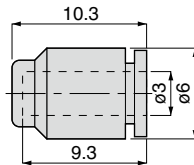

Metric thread type



OP P.754

3D CAD

CAD

Unit : mm

Model code	Weight (g)	CAD file name
PPF3M ④⑤	0.6	PPF3M

※ 1. ④ in Model code / Replaced with "W" for Light-gray color

※ 2. ⑤ in Model code / Replaced with "C" for Clean-room package



SAFETY Instructions

This safety instructions aim to prevent personal injury and damage to properties by requiring proper use of PISCO products.

Be certain to follow ISO 4414 and JIS B 8370

ISO 4414 : Pneumatic fluid power...Recommendations for the application of equipment to transmission and control systems.

JIS B 8370 : General rules and safety requirements for systems and their components.

This safety instructions is classified into "Danger", "Warning" and "Caution" depending on the degree of danger or damages caused by improper use of PISCO products.



Danger

Hazardous conditions. It can cause death or serious personal injury.



Warning

Hazardous conditions depending on usages. Improper use of PISCO products can cause death or serious personal injury.



Caution

Hazardous conditions depending on usages. Improper use of PISCO products can cause personal injury or damages to properties.



Warning

1. Selection of pneumatic products

- ① A user who is a pneumatic system designer or has sufficient experience and technical expertise should select PISCO products.
- ② Due to wide variety of operating conditions and applications for PISCO products, carry out the analysis and evaluation on PISCO products. The pneumatic system designer is solely responsible for assuring that the user's requirements are met and that the application presents no health or safety hazards. All designers are required to fully understand the specifications of PISCO products and constitute all systems based on the latest catalog or information, considering any malfunctions.

2. Handle the pneumatic equipment with enough knowledge and experience

- ① Improper use of compressed air is dangerous. Assembly, operation and maintenance of machines using pneumatic equipment should be conducted by a person with enough knowledge and experience.

3. Do not operate machine / equipment or remove pneumatic equipment until safety is confirmed.

- ① Make sure that preventive measures against falling work-pieces or sudden movements of machine are completed before inspection or maintenance of these machine.
- ② Make sure the above preventive measures are completed. A compressed air supply and the power supply to the machine must be off, and also the compressed air in the systems must be exhausted.
- ③ Restart the machines with care after ensuring to take all preventive measures against sudden movements.

Disclaimer

1. PISCO does not take any responsibility for any incidental or indirect loss, such as production line stop, interruption of business, loss of benefits, personal injury, etc., caused by any failure on use or application of PISCO products.
2. PISCO does not take any responsibility for any loss caused by natural disasters, fires not related to PISCO products, acts by third parties, and intentional or accidental damages of PISCO products due to incorrect usage.
3. PISCO does not take any responsibility for any loss caused by improper usage of PISCO products such as exceeding the specification limit or not following the usage the published instructions and catalog allow.
4. PISCO does not take any responsibility for any loss caused by remodeling of PISCO products, or by combinational use with non-PISCO products and other software systems.
5. The damages caused by the defect of Pisco products shall be covered but limited to the full amount of the PISCO products paid by the customer.



SAFETY INSTRUCTION MANUAL

PISCO products are designed and manufactured for use in general industrial machines. Be sure to read and follow the instructions below.

Danger

1. Do not use PISCO products for the following applications.
 - ① Equipment used for maintaining / handling human life and body.
 - ② Equipment used for moving / transporting human.
 - ③ Equipment specifically used for safety purposes.

Warning

1. Do not use PISCO products under the following conditions.
 - ① Beyond the specifications or conditions stated in the catalog, or the instructions.
 - ② Under the direct sunlight or outdoors.
 - ③ Excessive vibrations and impacts.
 - ④ Exposure / adhere to corrosive gas, inflammable gas, chemicals, seawater, water and vapor. *
 - * Some products can be used under the condition above(④), refer to the details of specification and condition of each product.
2. Do not disassemble or modify PISCO products, which affect the performance, function, and basic structure of the product.
3. Turn off the power supply, stop the air supply to PISCO products, and make sure there is no residual air pressure in the pipes before maintenance and inspection.
4. Do not touch the release-ring of push-in fitting when there is a working pressure. The lock may be released by the physical contact, and tube may fly out or slip out.
5. Frequent switchover of compressed air may generate heat, and there is a risk of causing burn injury.
6. Avoid any load on PISCO products, such as a tensile strength, twisting and bending. Otherwise, there is a risk of causing damage to the products.
7. As for applications where threads or tubes swing / rotate, use Rotary Joints, High Rotary Joints or Multi-Circuit Rotary Block only. The other PISCO products can be damaged in these applications.
8. Use only Die Temperature Control Fitting Series, Tube Fitting Stainless SUS316 Series, Tube Fitting Stainless SUS316 Compression Fitting Series or Tube Fitting Brass Series under the condition of over 60°C (140° F) water or thermal oil. Other PISCO products can be damaged by heat and hydrolysis under the condition above.
9. As for the condition required to dissipate static electricity or provide an antistatic performance, use EG series fitting and antistatic products only, and do not use other PISCO products. There is a risk that static electricity can cause system defects or failures.
10. Use only Fittings with a characteristic of spatter-proof such as Anti-spatter or Brass series in a place where flame and weld spatter is produced. There is a risk of causing fire by sparks.
11. Turn off the power supply to PISCO products, and make sure there is no residual air pressure in the pipes and equipment before maintenance. Follow the instructions below in order to ensure safety.
 - ① Make sure the safety of all systems related to PISCO products before maintenance.
 - ② Restart of operation after maintenance shall be proceeded with care after ensuring safety of the system by preventive measures against unexpected movements of machines and devices where pneumatic equipment is used.
 - ③ Keep enough space for maintenance when designing a circuit.
12. Take safety measures such as providing a protection cover if there is a risk of causing damages or fires on machine / facilities by a fluid leakage.

⚠ Caution

1. Remove dusts or drain before piping. They may get into the peripheral machine / facilities and cause malfunction.
2. When inserting an ultra-soft tube into push-in fitting, make sure to place an Insert Ring into the tube edge. There is a risk of causing the escape of tube and a fluid leakage without using an Insert Ring.
3. The product incorporating NBR as seal rubber material has a risk of malfunction caused by ozone crack. Ozone exists in high concentrations in static elimination air, clean-room, and near the high-voltage motors, etc. As a countermeasure, material change from NBR to HNBR or FKM is necessary. Consult with PISCO for more information.
4. Special option "Oil-free" products may cause a very small amount of a fluid leakage. When a fluid medium is liquid or the products are required to be used in harsh environments, contact us for further information.
5. In case of using non-PISCO brand tubes, make sure the tolerance of the outer tube diameter is within the limits of Table 1.

● Table 1. Tube O.D. Tolerance

mm size	Nylon tube	Polyurethane tube	inch size	Nylon tube	Polyurethane tube
ø1.8mm	—	± 0.05mm	ø1/8	± 0.1mm	± 0.15mm
ø3mm	—	± 0.15mm	ø5/32	± 0.1mm	± 0.15mm
ø4mm	± 0.1mm	± 0.15mm	ø3/16	± 0.1mm	± 0.15mm
ø6mm	± 0.1mm	± 0.15mm	ø1/4	± 0.1mm	± 0.15mm
ø8mm	± 0.1mm	± 0.15mm	ø5/16	± 0.1mm	± 0.15mm
ø10mm	± 0.1mm	± 0.15mm	ø3/8	± 0.1mm	± 0.15mm
ø12mm	± 0.1mm	± 0.15mm	ø1/2	± 0.1mm	± 0.15mm
ø16mm	± 0.1mm	± 0.15mm	ø5/8	± 0.1mm	± 0.15mm

6. Instructions for Tube Insertion

- ① Make sure that the cut end surface of the tube is at right angle without a scratch on the surface and deformations.
- ② When inserting a tube, the tube needs to be inserted fully into the push-in fitting until the tubing edge touches the tube end of the fitting as shown in the figure below. Otherwise, there is a risk of leakage.

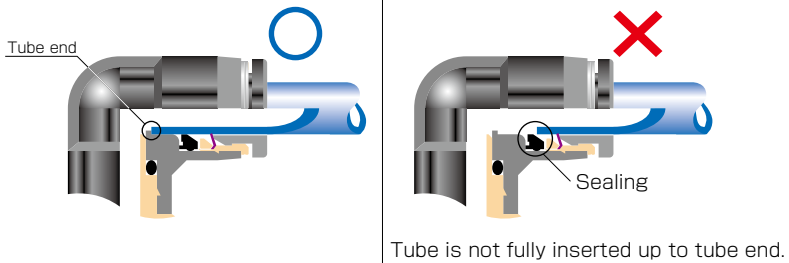

- ③ After inserting the tube, make sure it is inserted properly and not to be disconnected by pulling it moderately.
- ※ When inserting tubes, Lock-claws may be hardly visible in the hole, observed from the front face of the release-ring. But it does not mean the tube will surely escape. Major causes of the tube escape are the followings;
 - ① Shear drop of the lock-claws edge
 - ② The problem of tube diameter (usually small)
 Therefore, follow the above instructions from ① to ③, even lock-claws is hardly visible.

7. Instructions for Tube Disconnection

- ① Make sure there is no air pressure inside of the tube, before disconnecting it.
- ② Push the release-ring of the push-in fitting evenly and deeply enough to pull out the tube toward oneself. By insufficient pushing of the release-ring, the tube may not be pulled out or damaged by scratch, and tube shavings may remain inside of the fitting, which may cause the leakage later.

8. Instructions for Installing a fitting

- ① When installing a fitting, use proper tools to tighten a hexagonal-column or an inner hexagonal socket. When inserting a hex key into the inner hexagonal socket of the fitting, be careful so that the tool does not touch lock-claws. The deformation of lock-claws may result in a poor performance of systems or an escape of the tube.
- ② Refer to Table 2 which shows the recommended tightening torque. Do not exceed these limits to tighten a thread. Excessive tightening may break the thread part or deform the gasket and cause a fluid leakage. Tightening thread with tightening torque lower than these limits may cause a loosened thread or a fluid leakage.
- ③ Adjust the tube direction while tightening thread within these limits, since some PISCO products are not rotatable after the installation.

● Table 2: Recommended tightening torque / Sealock color / Gasket materials

Thread type	Thread size	Tightening torque	Sealock color	Gasket materials
Metric thread	M3 × 0.5	0.7N·m	—	SUS304 NBR
	M5 × 0.8	1.0 ~ 1.5N·m		
	M6 × 1	2 ~ 2.7N·m		
	M3 × 0.5	0.7N·m		POM
	M5 × 0.8	1 ~ 1.5N·m		
	M6 × 0.75	0.8 ~ 1N·m		
Taper pipe thread	M8 × 0.75	1 ~ 2N·m	White	—
	R1/8	4.5 ~ 6.5N·m		
	R1/4	7 ~ 9N·m		
	R3/8	12.5 ~ 14.5N·m		
Unified thread	R1/2	20 ~ 22N·m	—	SUS304, NBR
	No.10-32UNF	1.0 ~ 1.5N·m		
National pipe thread taper	1/16-27NPT	4.5 ~ 6.5N·m	White	—
	1/8-27NPT	4.5 ~ 6.5N·m		
	1/4-18NPT	7 ~ 9N·m		
	3/8-18NPT	12.5 ~ 14.5N·m		
	1/2-14NPT	20 ~ 22N·m		

※ These values may differ for some products. Refer to each specification as well.

9. Instructions for removing a fitting

- ① When removing a fitting, use proper tools to loosen a hexagonal-column or an inner hex bolt.
- ② Remove the sealant stuck on the mating equipment. The remained sealant may get into the peripheral equipment and cause malfunctions.

10. Arrange piping avoiding any load on fittings and tubes such as twist, tensile, moment load, shaking and physical impact. These may cause damages to fittings, tube deformations, bursting and the escape of tubes.

Common Safety Instructions for Fittings

Before selecting or using PISCO products, read the following instructions. Read the detailed instructions for individual series as well as the instructions below.

Warning

1. Do not use fittings with fluid medium other than air or water. (Water can be used with some series.) Contact us for using other kind of fluid medium except air and water.
2. Do not use fittings except Anti-spatter, Brass and Brass Compression Fitting series in a place where the flame and weld spatter is produced. There is a risk of causing fire by sparks.
3. As for applications where threads or tubes swing / rotate, use Rotary Joints, High Rotary Joints or Multi-Circuit Rotary Block only. The other PISCO products can be damaged in these applications.
4. Use only Die Temperature Control Fitting Series, Tube Fitting Stainless SUS316 Series, Tube Fitting Stainless SUS316 Compression Fitting Series or Tube Fitting Brass Series under the condition of over 60°C (140° F) water or thermal oil. Other PISCO products can be damaged by heat and hydrolysis under the condition above.
5. As for the condition required to dissipate static electricity or provide an antistatic performance, use EG Series fitting and antistatic products only, and do not use other PISCO products. There is a risk that static electricity can cause system defects or failures.
6. Avoid any load on PISCO products, such as a tensile strength, twisting and bending. Otherwise, there is a risk of causing damage to the products.

⚠ Caution

1. In case of using non-PISCO brand tubes, make sure the tolerance of the outer tube diameter is within the following limits of Table 1.

● Table 1. Tube O.D. Tolerance

mm size	Nylon tube	Urethane tube	inch size	Nylon tube	Urethane tube
ø1.8mm	—	± 0.05mm	ø1/8	± 0.1mm	± 0.15mm
ø3mm	—	± 0.15mm	ø5/32	± 0.1mm	± 0.15mm
ø4mm	± 0.1mm	± 0.15mm	ø3/16	± 0.1mm	± 0.15mm
ø6mm	± 0.1mm	± 0.15mm	ø1/4	± 0.1mm	± 0.15mm
ø8mm	± 0.1mm	± 0.15mm	ø5/16	± 0.1mm	± 0.15mm
ø10mm	± 0.1mm	± 0.15mm	ø3/8	± 0.1mm	± 0.15mm
ø12mm	± 0.1mm	± 0.15mm	ø1/2	± 0.1mm	± 0.15mm
ø16mm	± 0.1mm	± 0.15mm	ø5/8	± 0.1mm	± 0.15mm

2. Instructions for Tube Insertion

- ① Make sure that the cut end surface of the tube is at right angle without a scratch on the tube surface and deformations.
- ② When inserting a tube, the tube needs to be inserted fully into the push-in fitting until the tubing edge touches the tube end of the fitting as shown in the figure below. Otherwise, there is a risk of leakage.

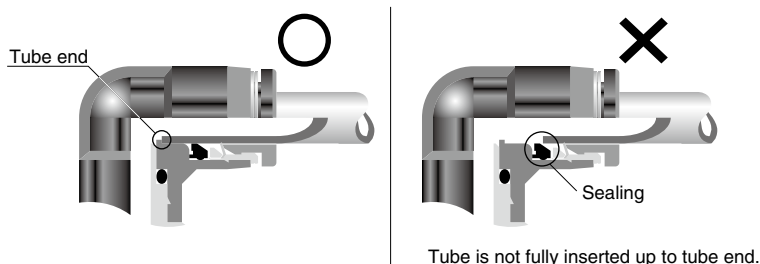

- ③ After inserting the tube, make sure it is inserted properly and not to be disconnected by pulling it moderately.

3. Instructions for Tube Disconnection

- ① Make sure there is no air pressure inside of the tube, before disconnecting it.
- ② Push the release-ring of the push-in fitting evenly and deeply enough to pull out the tube toward oneself. By insufficient pushing of the release-ring, the tube may not be pulled out or damaged by scratch, and tube shavings may remain inside of the fitting, which may cause the leakage later.

4. Instructions for Installing a fitting

- ① When installing a fitting, use proper tools to tighten a hexagonal-column or an inner hexagonal socket. When inserting a hex key into the inner hexagonal socket of the fitting, be careful so that the tool does not touch lock-claws. The deformation of lock-claws may result in a poor performance of systems or an escape of the tube.
- ② Refer to Table 2 which shows the recommended tightening torque. Do not exceed these limits to tighten a thread. Excessive tightening may break the thread part or deform the gasket and cause a fluid leakage. Tightening thread with tightening torque lower than these limits may cause a loosened thread or a fluid leakage.
- ③ Adjust the tube direction while tightening thread within these limits, since some PISCO products are not rotatable the installation.

● Table 2: Recommended tightening torque / Sealock color / Gasket materials

Thread type	Thread size	Tightening torque	Sealock color	Gasket materials
Metric thread	M3 × 0.5	0.7N·m	—	SUS304 NBR
	M5 × 0.8	1.0 ~ 1.5N·m		
	M6 × 1	2 ~ 2.7N·m		
	M3 × 0.5	0.5 ~ 0.6N·m		POM
	M5 × 0.8	1 ~ 1.5N·m		
	M6 × 0.75	0.8 ~ 1N·m		
	M8 × 0.75	1 ~ 2N·m		
Taper pipe thread	R1/8	7 ~ 9N·m	White	—
	R1/4	12 ~ 14N·m		
	R3/8	22 ~ 24N·m		
	R1/2	28 ~ 30N·m		
Unified thread	No.10-32UNF	1.0 ~ 1.5N·m	—	SUS304, NBR
National pipe thread taper	1/16-28NPT	7 ~ 9N·m	White	—
	1/8-27NPT	7 ~ 9N·m		
	1/4-18NPT	12 ~ 14N·m		
	3/8-18NPT	22 ~ 24N·m		
	1/2-14NPT	28 ~ 30N·m		

※. These values may differ for some products. Refer to each specification as well

5. Instructions for removing a fitting

- ① When removing a fitting, use proper tools to loosen a hexagonal-column or an inner hexagonal socket.
- ② Remove the sealant stuck on the mating equipment. The remained sealant may get into the peripheral equipment and cause malfunctions.

6. Arrange piping avoiding any load on fittings and tubes such as twist, tensile, moment load, shaking and physical impact. These may cause damages to fittings, tube deformations, bursting and the escape of tubes.

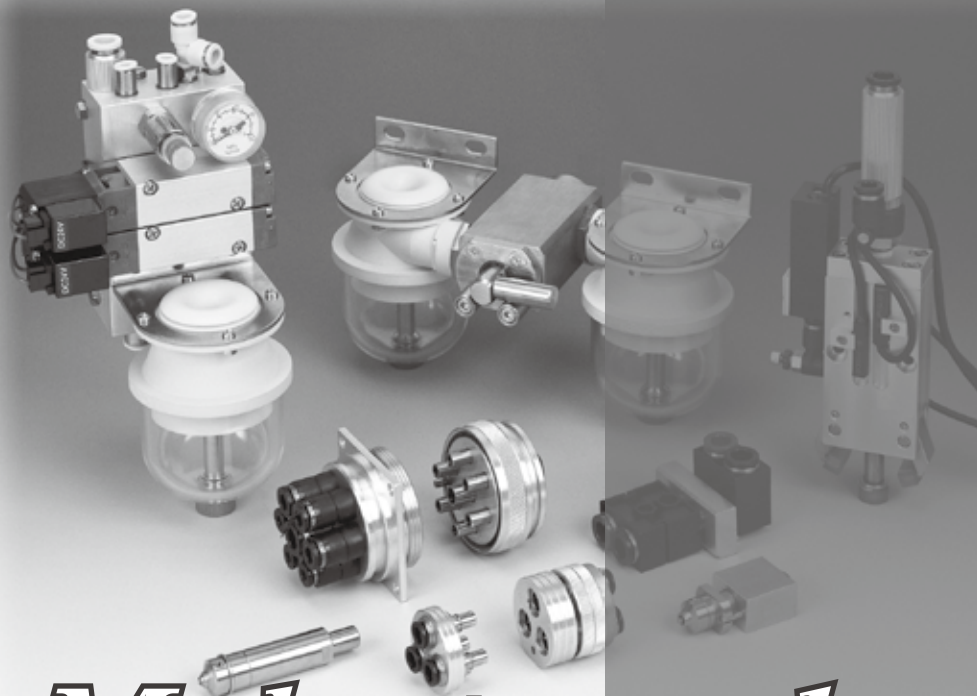

Make-to-order products

PISCO offers make-to-order products to support customer's various requirements such as special specifications, and special appearances.

Special Options

■ Characteristics

● *Color option*

Light-gray color option for resin body and release-ring.

● *Seal rubber material option*

Seal Rubber Selection: FKM or EPDM.

● *Oil-free option*

Suitable for Oil-free Environment.

● *Release-ring color option*

Changeable to Red Color

● *Non-purple option*

Suppress CU ion and F ion.

※ Note: With this option, Check Valve and Stop Fitting, etc. do not have marking on the brass parts. Be careful when piping.

Model Designation (Example)

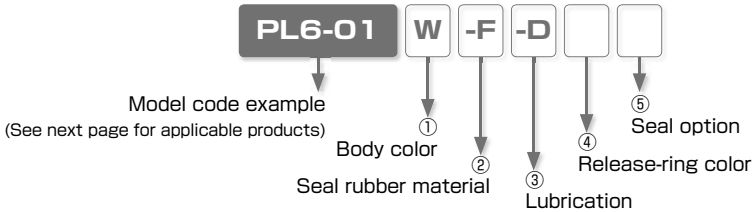

① Body color

Code	W	No code
Body color	Light-gray	Standard color

※ . W: Release-ring color is light-gray

② Seal rubber material

Code	-F	-E	No code
Material	FKM	EPDM (Oil-free)	Standard seal rubber

※ 1. FKM: Release-ring color is brown. Non-purple option is not available with FKM option.

※ 2. EPDM: All oil-free. Release-ring color is yellow.

※ 3. EPDM: Not available for Thread size M3, M6 and Fittings with Inch sized Tube dia.

③ Lubrication

Code	-D	No code
Option	Oil-free	Standard lubrication

※ 1. Oil-free : Release-ring color is yellow.

※ 2. The products with oil-free option are assembled without intentional use of lubrication through its production process. It may cause problems such as degradation of airtightness and increase of friction.

④ Release-ring color

Code	-R	No code
Color	Red	Standard color

⑤ Seal option (Taper pipe thread only)

Code	-P	No code
Option	Non-purple	Standard

※ 1. Non-purple option is not available with seal rubber FKM

※ . See next page for "Reference Chart of Special Option" .

※ . Contact the nearest sales office for the price.

Reference Chart of Special Option

○ : Available, × : Not available

Series	Standard specification						Special specification					
	Body Color and Packaging Option	Body color	Release-ring color	Seal rubber material	Lubrication	Seal option	①	②	③	④	⑤	
							Body color	Seal rubber material	Lubrication	Release-ring color	Seal option	
							W* ¹	-F* ²	-E* ³	-D* ⁴	-R	-P* ²
Light-gray	FKM	EPDM	Oil-free	Red	Non-purple							
Tube Fitting Standard Series	—	Black	Black	NBR	Turbin oil	With seal coat	—	○* ⁵	○	○	○	○
	Light-gray	Light-gray	Light-gray				Std. option	○	○	○	×	○
	Clean-room pkg	Light-gray	Light-blue		Fluorochemical grease	—	○	○* ⁶	○* ⁶	×	×	
	Light-gray + Clean-room pkg	Light-gray	Light-gray		Std. option	○	○	○	×	×		
Tube Fitting Mini Series	—	Black	Black	NBR	Turbin oil	With seal coat	—	○* ⁵	○	○	○	○
	Light-gray	Light-gray	Light-gray				Std. option	○	○	○	×	○
	Clean-room pkg	Light-gray	Light-blue		Fluorochemical grease	—	○	○* ⁶	○* ⁶	×	×	
	Light-gray + Clean-room pkg	Light-gray	Light-gray		Std. option	○	○	○	×	×		
Tube Fitting Stainless SUS304 Series	—	Black	Dark-blue	FKM	Turbin oil	With seal coat	×	Std. spec.	×	○* ⁷	×	×
Tube Fitting Stainless SUS303 Equivalent Corrosivity Series	—	Black	Dark-blue	HNBR	Turbin oil	With seal coat	○	○	○* ⁷	○* ⁷	×	○
Tube Fitting EG Series	—	Black	Black	NBR	Turbin oil	With seal coat	×	○	○* ⁸	×	×	○
Tube Fitting Brass Series	—	—	—	HNBR / FM / NBR	Turbin oil	With seal coat	×	Std. option	○	○	×	○
Tube Fitting Long Type	—	—	Black	NBR	Turbin oil	With seal coat	×	○* ⁵	○	○	○	○
Speed Controller Series	—	Black	Black	NBR	Turbin oil	With seal coat	—	○* ⁵	×	×	○	○
	Light-gray	Light-gray	Light-gray				Std. option	○	×	×	×	○
	Clean-room pkg	Light-gray	Light-blue		Fluorochemical grease	—	○	×	×	×	×	
	Light-gray + Clean-room pkg	Light-gray	Light-gray		Std. option	○	×	×	×	×		
Speed Controller SUS303 Equivalent Corrosivity	—	Black	Dark-blue	HNBR	Turbin oil	With seal coat	○	○	×	×	×	○
Throttle (Needle) Valve Standard Series	—	Black	Black	NBR	Turbin oil	With seal coat	—	○* ⁵	×	×	○	○
	Light-gray	Light-gray	Light-gray				Std. option	○	×	×	×	○
	Clean-room pkg	Light-gray	Light-blue		Fluorochemical grease	—	○	×	×	×	×	
	Light-gray + Clean-room pkg	Light-gray	Light-gray		Std. option	○	×	×	×	×		
Fixed Orifice Joint Series	—	Black	Black	NBR	Turbin oil	With seal coat	○	○	○	○	○* ⁹	○
Regulator Series (RVC, RVS, RVU, RVCU, RVUM)	—	Black	Black	NBR	Turbin oil	With seal coat	○	×	×	×	○* ⁹	○
Check Valve Series	—	Black	Black	NBR	Turbin oil	With seal coat	○* ¹⁰	×	×	×	○* ⁹	○
Check Valve Series (Resin Type)	—	Light-gray	Light-gray	NBR	Turbin oil	With seal coat	Std. option	×	×	×	×	○

※ 1. W: Release-ring color is light-gray

※ 2. Seal option non-purple is not available with seal rubber material FKM

※ 3. EPDM: All oil-free. Release-ring color is yellow. Thread size M3, M6 and Fitting with inch sized Tube dia are not available.

※ 4. Release-ring color: Yellow.

※ 5. Release-ring color: Brown.

※ 6. Release-ring color: Light-blue.

※ 7. Release-ring color: Dark-blue.

※ 8. Release-ring color: Black

※ 9. Release-ring Red is not selectable with body color Light-gray.

















※ 10. Not available for CVU4-4, CVU6-6 and CVU8-8.

※ Contact the nearest sales office for other special specifications.

■ Reference chart of Appearance Color Combination (For Fitting)

Series	Resin color or Option	Tube dia.		Seal rubber material		Lubrication	Release-ring color	
				-F FKM	-E EPDM	-D Oil-free	-R Red	
Tube Fitting Standard Series Tube Fitting Mini Series	-	mm size						
		inch size						
	Light-gray	mm size						
		inch size						
	Clean-room pkg	mm size						
		inch size						
	Light-gray + Clean-room pkg	mm size						
		inch size						
	Tube Fitting Stainless SUS304 Series	-	mm size		Std. spec.			
	Tube Fitting Stainless SUS303 Equivalent Corrosivity Series	-	mm size					
		Light-gray	mm size					

Reference chart of Appearance Color Combination (For Controller)

Series	Resin color or Option	Tube dia.		Seal rubber material		Release-ring color
				-F FKM	-R レッド	
Speed Controller Series Throttle (Needle) Valve Standard Series	-	mm size				
		inch size				
	Light-gray	mm size				
		inch size				
	Clean-room pkg	mm size				
		inch size				
	Light-gray + Clean-room pkg	mm size				
		inch size				

Space-Saving Options

Characteristics

- Suitable for Installing in Limited Spaces.

Model Designation (Example)

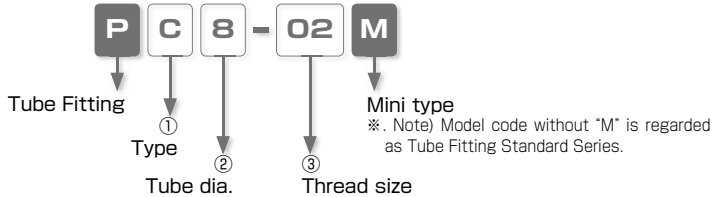

① Type

Code	Type	Code	Type	Code	Type
L	Elbow	B	Branch Tee	D	Run Tee

② Tube dia.

Code	8	10
Size (mm)	ø8	ø10

③ Thread size

Thread size	Taper pipe thread		
Code	01	02	03
Size	R1/8	R1/4	R3/8

Make-to-order products

FITTING
CONTROLLER
VALVE
TUBE



Elbow

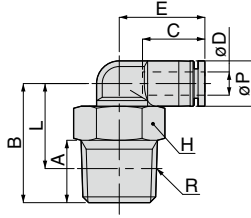

Unit : mm

Model code	Tube O.D. ϕD	R	A	B	Tube end C	L	Hex. H	E	ϕP	Weight (g)
PL8-01M	8	R1/8	8	22.5	18.1	18.5	12	21.9	15	11.9
PL8-02M		R1/4	11	25.5		19.5	14			17.5
PL8-03M		R3/8	12	26.5		20.2	17			27.9
PL10-02M	10	R1/4	11	27	20.2	21	14	24.4	18	20.9
PL10-03M		R3/8	12	28		21.7	17			28.8

※ . "L" is a reference value for height dimension after tightening thread.

MAKE-TO-ORDER
PRODUCTS

761



Branch Tee

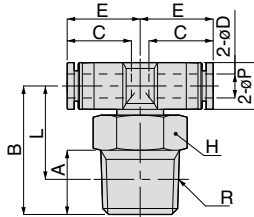

Unit : mm

Model code	Tube O.D. ϕD	R	A	B	Tube end C	L	Hex. H	E	ϕP	Weight (g)
PB8-01M	8	R1/8	8	22.5	18.1	18.5	12	21.9	15	12.8
PB8-02M		R1/4	11	25.5		19.5	14			18.2
PB8-03M		R3/8	12	26.5		20.2	17			26.1
PB10-02M	10	R1/4	11	27	20.2	21	14	24.4	18	22.3
PB10-03M		R3/8	12	28		21.7	17			30.4

※ . "L" is a reference value for height dimension after tightening thread.



Run Tee

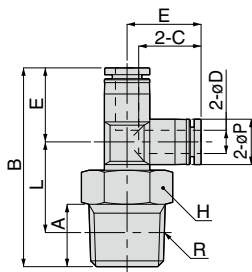

Unit : mm

Model code	Tube O.D. øD	R	A	B	Tube end C	L	Hex. H	E	øP	Weight (g)
PD8-01M	8	R1/8	8	44.2	18.1	18.5	12	21.7	15	11.9
PD8-02M		R1/4	11	47.2		19.5	14			17.5
PD8-03M		R3/8	12	48.2		20.2	17			25.3
PD10-02M	10	R1/4	11	52.3	20.2	21	14	25.3	18	21
PD10-03M		R3/8	12	53.3		21.7	17			28.8

※ .L" is a reference value for height dimension after tightening thread.